

SCL



SCL 3/S
SCL 3/N
SCL 8
SBR
SCT



SCL 2



SCL 9
SCL 10



SCL 11

EN

OPERATING MANUAL

CLOSED AMPEROMETRIC CELLS

R5-03-24

GENERAL SAFETY GUIDELINES	3
PURPOSE OF USE AND SAFETY	4
ENVIRONMENTAL SAFETY.....	5
LABELS.....	5
SPARE PARTS.....	5
INTRODUCTION.....	7
Closed amperometric cells	7
Packaging	7
SCL3S	9
SCL3N	10
SCL8	11
SCL2	12
SCL9	13
SCL10	14
SCL11	15
SBR.....	16
SCT.....	17
Operating principle.....	18
Precautions	18
Preparation	19
Probe alignment procedure.....	21
Cleaning procedure	22
Installation on PEF.....	23
MAINTENANCE	24
Maintenance schedule.....	24
Maintenance inspection	24
Decommissioning	24
Dimension (mm).....	25
TROUBLESHOOTING	26



This operating instructions contains safety information that if ignored can endanger life or result in serious injury.

The original instruction is in English.

Read these instructions **carefully** before use and keep them for future reference.

Information and specifications on this manual could be uncorrect or could have printing errors. Specifications are subject to change without notice.

Version: R3-05-21



NORME CE
EC RULES (STANDARD EC)
NORMAS DE LA CE

Direttiva Bassa Tensione
Low Voltage Directive
Directiva de baja tensión

} 2014/35/UE

Direttiva EMC Compatibilità Elettromagnetica
EMC electromagnetic compatibility directive
EMC directiva de compatibilidad electromagnética

} 2014/30/UE

GENERAL SAFETY GUIDELINES

Operating, installing, or maintaining the unit in any way that is not covered in this manual could cause death, serious personal injury, or damage to the equipment.

ICON

This manual use the following safety message icon:



Danger!

Indicates a hazardous situation which, if not avoided, will result in death or serious injury.



Warning!

Indicates a hazardous situation which, if not avoided, could result in death or serious injury.



Important - A practice not related to personal injury or additional information.



Cross reference - An instance which refers to related information elsewhere in the same document

**PURPOSE OF USE
AND SAFETY**

**EQUIPMENT INTENDED FOR THE MEASUREMENT OF CHLORINE (OR ITS ABSENCE) IN
WATER.**

Do not use in explosive area (EX).
Do not use with flammable chemical .
Do not use with radioactive chemicals.

Use the probe in accordance with the data and specifications printed on the label

Do not modify or use in a manner inconsistent with the provisions of the operating manual.

- ⚠** When using this product with aggressive chemicals observe the regulations concerning the transport and storage of aggressive fluids.
- ⚠** When installing always observe national regulations.
- ⚠** Manufacturer is not liable for any unauthorized use or misuse of this product that may cause injury, damage to persons or materials.
- ⚠** Probes must be serviced and repaired by qualified and authorized personnel only.
- ⚠** Before any operation:
 - always read chemical Material Safety Data Sheet (MSDS);
 - always wear protective clothing;
 - empty and rinse the liquid end before work on a the product which has been used with hazardous or unknown chemicals.
- ⚠** Avoid grinding / shock / falls / friction.

Environmental safety

Work area

Always keep the area clean to avoid and/or discover emissions.

Recycling guidelines

EWC code: 16 02 16

Always recycle according to these guidelines:

1. If the unit or parts are accepted by an authorized recycling company, then follow local recycling laws and regulations.
2. If the unit or parts are not accepted by an authorized recycling company, then return them to the nearest representative.

Waste and emissions regulations

Observe these safety regulations regarding waste and emissions:

- Dispose appropriately of all waste.
- Handle and dispose of the dosed chemical in compliance with applicable environmental regulations.
- Clean up all spills in accordance with safety and environmental procedures.
- Report all environmental emissions to the appropriate authorities.

LABELS

On the box (example)

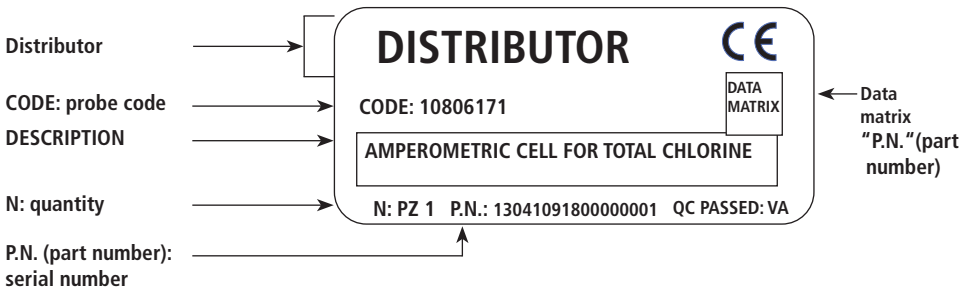

On the probe (example)

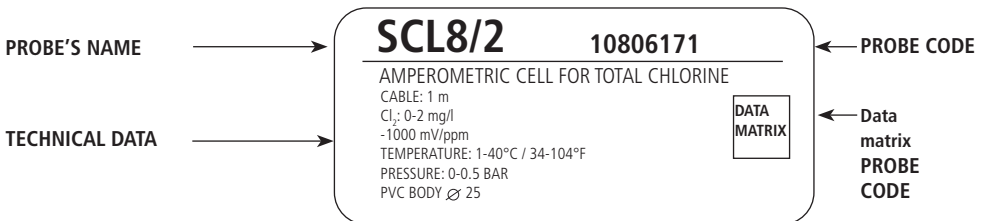

Spare parts

For spare parts orders or any other communication, refer to the pump's label. Code (CODE) and serial number (P / N) uniquely identify the probe.

Transportation and storage

 An unsuitable transportation or storage can cause damages.

Use original box to pack the probe.

Observe storage conditions also for transportation.

Although packed, always protect the unit against humidity and the action of chemicals.

 Before returning the probe to the manufacturer repair service, clean and rinse it. Disassemble the membrane cap and discard electrolyte.

 DO NOT DISCARD PACKAGING. USE IT TO RETURN THE PROBE.

Storage

To store the probe:

1. Decommission the probe

2. Store the probe in the original box, protected against sun, chemicals and humidity.

Transportation and storage temperature +10°C - +50°C (+32°F - +122°F)

Humidity 95% relative humidity (not condensed)

INTRODUCTION

Closed amperometric cells

They are equipped with a special membrane system.
SCL 3 and 8 work in chlorine water system.

Absence of chlorine for more than 100 hours damage the probe.

The probe has to be installed into a probe holder and connected to a measuring and control instrument.

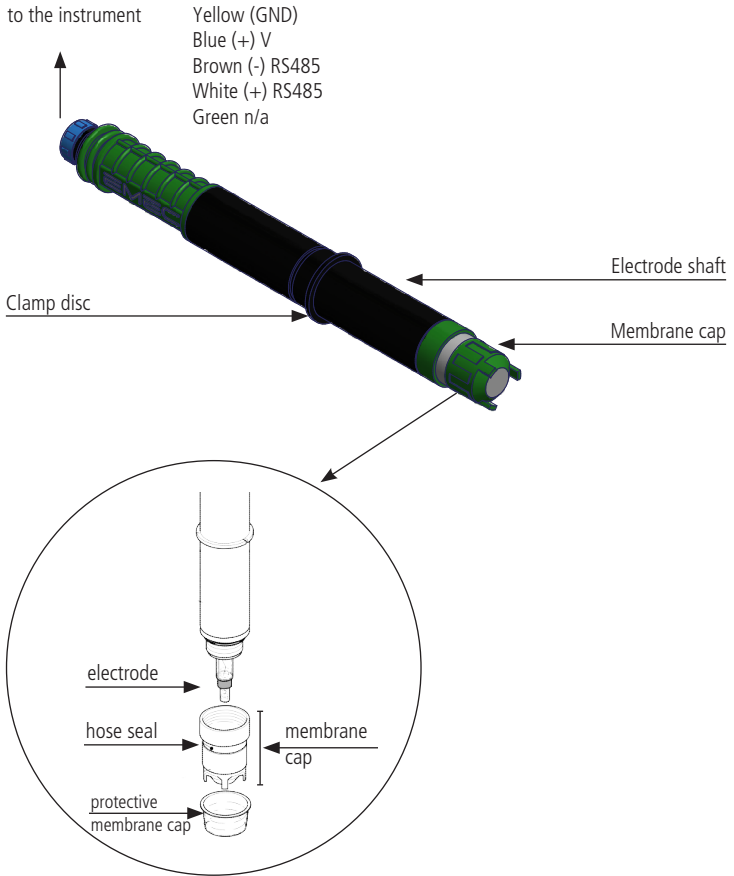

Packaging

The packaging will include the following:

- Sensor complete with sensor cap, protective cap and clamp ring
- Connector cable
- electrolyte
- operating manual

MODELS

- SCLS3 for free chlorine (organic and inorganic) for fresh water
- SCL3N for free chlorine (inorganic) for fresh water
- SCL8 for total chlorine
- SCL2 for chlorine dioxide
- SCL9 for hydrogen peroxyde
- SCL10 for ozone
- SCL 11 for peracetic acid
- SBR for bromine
- SCT for chlorite

WARNING:

Before to change membrane assure to install the correct one:

SCL / SVCL 3S must use labeled "A" membrane

SCL / SVCL 3N must use labeled "B" membrane

	SCL35
Parameter	FREE CHLORINE (ORGANIC) FOR FRESH WATER
Measuring range	SCL35/20: 0,1-20 mg/l (0,1-20 ppm)
Voltage supply	0/5 VDC ($\pm 10\%$) - 10 mA
Connection	5-pole screw connector
Measuring system	membrane covered, amperometric potentiostatic 2-electrode system
Ph working range	5,5-9,5 pH
Sample water conductivity	30-10.000 $\mu\text{S}/\text{cm}$
Run-in-time	First commissioning: 6 h approx. Recommissioning: 3 h approx.
Response time	T_{90} : 2 min. approx.
Zero point adjustment	see chapter "Probe alignment"
Slope calibration	see chapter "Probe alignment" DPD1 method
Alcalinity	100 ppm
Working temperature	1-40° C (34-104°F) with temperature compensation
Max pressure	1 bar - 10 mwc [mH ₂ O] no pressure impulses and/or vibration, no depressure
Power supply	4 wires
Cable (standard)	1 m (3.28 ft)
Electrolyte mod.	ELESCL3
Membrane mod.	MESCL3
Working flow	30 l/h
Suitable for probe holder mod.	PEF1, PEF1/E, PEF5, PEF23
Material	Membrane cap: PC/ABS Shaft: PE
Storage	probe: frost-protected, dry and without electrolyte (5-40°C) membrane cap: 1 year, depending on water quality electrolyte: in original bottle, protect from sunlight (5-25°C). Expiration date on the label.
Maintenance	regular control of measuring signal change electrolyte: every 3-6 months SHORTEN THE MAINTENANCE INTERVALS APPROPRIATELY DEPENDING ON WATER QUALITY.
Dimension	Diam.: 25 mm Length: 241 mm

	SCL3N
Parameter	FREE CHLORINE (INORGANIC) FOR FRESH WATER
Measuring range	SCL3N/2: 0-2 mg/l (0-2 ppm) resolution: ± 0.001 SCL3N/20: 0-20 mg/l (0-20 ppm) resolution: ± 0.01 SCL3N/200: 0-200 mg/l (0-200 ppm) resolution: ± 0.1
Voltage supply	0/5 VDC ($\pm 10\%$) - (10 mA)
Connection	5-pole screw connector
Measuring system	membrane covered, amperometric 2-electrode system
Ph working range	5-9.5 pH, reduced dependance on pH value. When the pH value increases, the measured signal decreases at about 10% per pH unit.
Water sample conductivity	30 $\mu\text{S}/\text{cm}$ - 10000 $\mu\text{S}/\text{cm}$
Run-in-time	first start up 1-24 h (6 hours usually) depending on water quality
Response time	T_{90} : 2 min. approx.
Zero point adjustment	See Operating manual: "Probe alignment"
Slope calibration	See Operating manual: "Probe alignment" DPD1 method
Alcalinity	80 ppm
Working temperature	1-40° C (34-104°F)
Temperature compensation	automatically, by an integrated temperature sensor
Max pressure	1 bar - 10 mwc [mH ₂ O] no pressure impulses and/or vibration, no depressure
Power supply	4 wires
Cable (standard)	1 m (3.28 ft)
Electrolyte mod.	ELESCL3N
Membrane mod.	MESCL3
Working flow	30 l/h
Suitable for probe holder mod.	PEF1, PEF1/E, PEF5, PEF23
Material	Shaft: PE; Membrane cap: PC/ABS
Storage	probe: frost-protected, dry and without electrolyte (5-40° C) membrane cap: used membrane cap can not be stored electrolyte: in original bottle, protect from sunlight (5-25°C) Expiration date on the label.
Maintenance	regular control of measuring signal change electrolyte: every 3-6 months SHORTEN THE MAINTENANCE INTERVALS APPROPRIATELY DEPENDING ON WATER QUALITY.
Dimension	Diam.: 25 mm Length: 241 mm

	SCL8
Parameter	TOTAL CHLORINE
Measuring range	SCL8/2: 0-2 mg/l (0-2 ppm) resolution: ± 0.001 SCL8/20: 0-20 mg/l (0-20 ppm) resolution: ± 0.01
Voltage supply	0/5 VDC ($\pm 10\%$) - (10 mA)
Connection	5-pole screw connector
Measuring system	membrane covered, amperometric 2-electrode system
Ph working range	6.5-9.5 pH, reduced dependence on pH value. When the pH value increases, the measured signal decreases at about 10% per pH unit.
Water sample conductivity	0.03 - 40 mS/cm
Run-in-time	first start up 24 h approx.
Response time	T_{90} : 60 s approx.
Zero point adjustment	See Operating manual: "Probe alignment"
Slope calibration	See Operating manual: "Probe alignment" DPD4 method
Alcalinity	80 ppm
Working temperature	1-40° C (34-104°F)
Temperature compensation	automatically, by an integrated temperature sensor
Max pressure	1 bar (14.5 PSI) - 10 mwc [mH ₂ O] no pressure impulses and/or vibration, no depressure
Power supply	4 wires
Cable (standard)	1 m (3.28 ft)
Electrolyte mod.	ELESCL8
Membrane mod.	MESCL8/2 or MESCL8/20
Working flow	30 l/h
Suitable for probe holder mod.	PEF1, PEF1/E, PEF5, PEF23
Material	Shaft: PE; Membrane cap: PC/ABS
Storage	probe: frost-protected, dry and without electrolyte (5-40° C) membrane cap: used membrane cap can not be stored electrolyte: in original bottle, protect from sunlight (5-25° C) Expiration date on the label.
Maintenance	regular control of measuring signal change electrolyte: every 3-6 months SHORTEN THE MAINTENANCE INTERVALS APPROPRIATELY DEPENDING ON WATER QUALITY.
Dimension	Diam.: 25 mm Length: 241 mm

Parameter	CHLORINE DIOXIDE
Measuring range	SCL2/2: 0-2 mg/l (0-2 ppm) resolution: ± 0.001 SCL2/20: 0-20 mg/l (0-20 ppm) resolution: ± 0.01
Voltage supply	0/5 VDC ($\pm 10\%$) - (10 mA)
Connection	5-pole screw connector
Measuring system	membrane covered, 2-electrode system
Ph working range	4-11 pH
Run-in-time	first start up 1-24 h approx. (usually 6 h)
Response time	T ₉₀ : 15 sec.. approx.
Zero point adjustment	See Operating manual: "Probe alignment"
Slope calibration	See Operating manual: "Probe alignment"
Alcalinity	80 ppm
Working temperature	1-40° C (34-104°F)
Temperature compensation	automatically, by an integrated temperature sensor
Max pressure	1 bar (14.5 PSI) - 10 mwc [mH2O] no pressure impulses and/or vibration, no depressure
Power supply	4 wires
Cable (standard)	1 m (3.28 ft)
Electrolyte mod.	ELESCL2
Membrane mod.	MESCL1-2
Working flow	30 l/h
Suitable for probe holder mod.	PEF1, PEF1/E, PEF5, PEF23
Material	Shaft: PVC; membrane cap: PPE.
Storage	probe: frost-protected, dry and without electrolyte (5-40° C) membrane cap: used membrane cap can not be stored electrolyte: in original bottle, protect from sunlight (5-25°C) Expiration date on the label.
Maintenance	regular control of measuring signal change electrolyte: every 3-6 months SHORTEN THE MAINTENANCE INTERVALS APPROPRIATELY DEPENDING ON WATER QUALITY.
Dimension	Diam.: 25 mm Length: 241 mm

Parameter	HYDROGEN PEROXIDE
Measuring range	SCL9/200: 0-200 mg/l (0-200 ppm) ; SCL9/50: 0-50 mg/l (0-50 ppm) res. \pm 0.1
Voltage supply	0/5 VDC (\pm 10%) - 25 mA
Connection	5-pole screw connector
Measuring system	membrane covered, amperometric electrode system
Ph working range	1-11 pH
Water sample conductivity	0.05 - 5.00 mS/cm
Run-in-time	first start up 2-6 h approx.
Response time	T ₉₀ : 10 min. approx.
Zero point adjustment	See Operating manual: "Probe alignment"
Slope calibration	See Operating manual: "Probe alignment"
Alcalinity	80 ppm
Working temperature	1-40° C (34-104°F)
Temperature compensation	automatically, by an integrated temperature sensor
Max pressure	1 bar (14.5 PSI) - 10 mwc [mH ₂ O] no pressure impulses and/or vibration, no depressure
Power supply	4 wires
Cable (standard)	1 m (3.28 ft)
Electrolyte mod.	ELESCL9
Membrane mod.	MESCL9
Working flow	30 l/h
Suitable for probe holder mod.	PEF1, PEF1/E, PEF5, PEF23
Material	Shaft: PVC-C; membrane cap: PVDF, PVC
Storage	probe: frost-protected, dry and without electrolyte (5-40° C) membrane cap: used membrane cap can not be stored electrolyte: in original bottle, protect from sunlight (5-25°C) Expiration date on the label.
Maintenance	regular control of measuring signal change electrolyte: every 3-6 months SHORTEN THE MAINTENANCE INTERVALS APPROPRIATELY DEPENDING ON WATER QUALITY.
Dimension	Diam.: 25 mm Length: 241 mm

Parameter	OZONE
Measuring range	SCL10/2: 0-2 mg/l (0-2 ppm) resolution: ± 0.001 SCL10/20: 0-20 mg/l (0-20 ppm) resolution: ± 0.01
Voltage supply	0/5 VDC ($\pm 10\%$) -10 mA
Connection	5-pole screw connector
Measuring system	membrane covered, amperometric 2-electrode system
Ph working range	2-11 pH
Run-in-time	first start up 1 h approx.
Response time	T_{90} : 50 sec. approx.
Zero point adjustment	See Operating manual: "Probe alignment"
Slope calibration	See Operating manual: "Probe alignment"
Alcalinity	80 ppm
Working temperature	1-40° C (34-104°F)
Temperature compensation	automatically, by an integrated temperature sensor
Max pressure	1 bar (14.5 PSI) - 10 mwc [mH2O] no pressure impulses and/or vibration, no depressure
Power supply	4 wires
Cable (standard)	1 m (3.28 ft)
Electrolyte mod.	ELSCL10
Membrane mod.	MSCL10
Working flow	30 l/h
Suitable for probe holder mod.	PEF1, PEF1/E, PEF5, PEF23
Material	PVC-U, stainless steel 1.4571
Storage	probe: frost-protected, dry and without electrolyte (5-40° C) membrane cap: used membrane cap can not be stored electrolyte: in original bottle, protect from sunlight (5-25°C) Expiration date on the label.
Maintenance	regular control of measuring signal change electrolyte: every 3-6 months SHORTEN THE MAINTENANCE INTERVALS APPROPRIATELY DEPENDING ON WATER QUALITY.
Dimension	Diam.: 25 mm Length: 241 mm

Parameter	PERACETIC ACID
Measuring range	SCL11/200: 0-200mg/l (0-200 ppm) resolution: ± 0.1 SCL11/2000: 0-2000 mg/l (0-2000 ppm) resolution: ± 1
Voltage supply	0/5 VDC ($\pm 10\%$) -10 mA
Connection	5-pole screw connector
Measuring system	membrane covered, amperometric 2-electrode system
Ph working range	1-9 pH
Run-in-time	first start up 1 h approx.
Response time	T_{90} : 3 min. approx.
Zero point adjustment	See Operating manual: "Probe alignment"
Slope calibration	See Operating manual: "Probe alignment"
Alcalinity	80 ppm
Working temperature	1-40° C (34-104°F)
Temperature compensation	automatically, by an integrated temperature sensor
Max pressure	1 bar (14.5 PSI) - 10 mwc [mH2O] no pressure impulses and/or vibration, no depressure
Power supply	4 wires
Cable (standard)	1 m (3.28 ft)
Electrolyte mod.	ELESCL11
Membrane mod.	MESCL11
Working flow	30 l/h
Suitable for probe holder mod.	PEF1, PEF1/E, PEF5, PEF23
Material	PVC-U, stainless steel 1.4571
Storage	probe: frost-protected, dry and without electrolyte (5-40° C) membrane cap: used membrane cap can not be stored electrolyte: in original bottle, protect from sunlight (5-25°C) Expiration date on the label.
Maintenance	regular control of measuring signal change electrolyte: every 3-6 months SHORTEN THE MAINTENANCE INTERVALS APPROPRIATELY DEPENDING ON WATER QUALITY.
Dimension	Diam.: 25 mm Length: 241 mm

Parameter	BROMINE
Measuring range	SBR/20: 0-20mg/l (0-20 ppm) resolution: ± 0.01
Voltage supply	0/5 VDC ($\pm 10\%$) -10 mA
Connection	5-pole screw connector
Measuring system	membrane covered, amperometric 2-electrode system
Ph working range	6.5-9.5 pH
Water sample conductivity	50 $\mu\text{S}/\text{cm}$ - 10000 $\mu\text{S}/\text{cm}$
Run-in-time	first start up 1-24 h approx. (usually 6 h)
Response time	T_{90} : 2 min. approx.
Zero point adjustment	See Operating manual: "Probe alignment"
Slope calibration	See Operating manual: "Probe alignment"
Alcalinity	80 ppm
Working temperature	1-40° C (34-104°F)
Temperature compensation	automatically, by an integrated temperature sensor
Max pressure	0.5 bar (7 PSI) - 5 mwc [mH ₂ O] no pressure impulses and/or vibration, no depressure
Power supply	4 wires
Cable (standard)	1 m (3.28 ft)
Electrolyte mod.	ELESBR
Membrane mod.	MESBR
Working flow	30 l/h
Suitable for probe holder mod.	PEF1, PEF1/E, PEF5, PEF23
Material	Shaft: PVC; membrane cap: PPE
Storage	probe: frost-protected, dry and without electrolyte (5-40° C) membrane cap: used membrane cap can not be stored electrolyte: in original bottle, protect from sunlight (5-25°C) Expiration date on the label.
Maintenance	regular control of measuring signal change electrolyte: every 3-6 months SHORTEN THE MAINTENANCE INTERVALS APPROPRIATELY DEPENDING ON WATER QUALITY.
Dimension	Diam.: 25 mm Length: 241 mm

Parameter	CHLORITE
Measuring range	SCT/2: 0-2mg/l (0-2 ppm) resolution: ± 0.001
Voltage supply	0/5 VDC ($\pm 10\%$) -10 mA
Connection	5-pole screw connector
Measuring system	membrane covered, amperometric 2-electrode system
pH range	5.5-9.5 pH
Conductivity range	0.05-5 mS/cm
Run-in-time	first start up 1-24 h approx. (usually 6 h)
Response time	T_{90} : 60 s approx.
Zero point adjustment	See Operating manual: "Probe alignment"
Slope calibration	See Operating manual: "Probe alignment"
Alcalinity	100 ppm
Working temperature	1-40° C (34-104°F)
Temperature compensation	automatically, by an integrated temperature sensor
Max pressure	1 bar (14.5 PSI) - 10 mwc [mH2O] no sbalzi di pressione, no depressione
Power supply	4 wires
Cable (standard)	1 m (3.28 ft)
Electrolyte mod.	ELESCT
Membrane mod.	MESCT
Working flow	30 l/h
Suitable for probe holder mod.	PEF1, PEF1/E, PEF5, PEF23
Material	Shaft: PVC; membrane cap: PPE
Storage	probe: frost-protected, dry and without electrolyte (5-40° C) membrane cap: used membrane cap can not be stored electrolyte: in original bottle, protect from sunlight (5-25°C) Expiration date on the label.
Maintenance	regular control of measuring signal change electrolyte: every 3-6 months SHORTEN THE MAINTENANCE INTERVALS APPROPRIATELY DEPENDING ON WATER QUALITY.
Dimension	Diam.: 25 mm Length: 241 mm

Operating principle

SCL probes are membrane covered amperometric electrode systems. The measuring electrode is membrane covered and it is in the electrolyte area together with the reference electrode. Electrolyte area contains a special electrolyte and it is separated from the measuring water.

SCL probes measuring method is an electrochemical technique that measures the changes in current resulting from chemical reaction as function of the analyte concentration.

Precautions

Before any operation (preparation, cleaning and replacements) and before handling the probe you MUST FOLLOW these PRECAUTIONS.



⚠ DANGER

AUTHORIZED AND QUALIFIED PERSONNEL

Installation and maintenance tasks should be carried out by **AUTHORIZED AND QUALIFIED PERSONNEL** only in accordance with local regulations.



⚠ DANGER

WEAR UNPOWDERED NITRILE GLOVES.

Avoid contact of the electrolyte with the skin.

In case of contact with skin, rinse immediately with plenty of water.



⚠ DANGER

WEAR EYE PROTECTION

Avoid contact of the electrolyte with the eyes.

In case of contact with eyes, rinse immediately with plenty of water and seek medical advice.

ELECTROLYTE Preparation

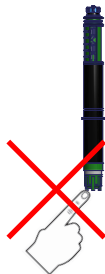

i IMPORTANT

DO NOT TOUCH OR DAMAGE THE MEMBRANE AT THE BOTTOM OF THE MEMBRANE CAP AND THE ELECTRODES AT THE BOTTOM OF THE ELECTRODE SHAFT OR BRING THEM INTO CONTACT WITH GREASY SUBSTANCES.

OTHERWISE THE SENSOR WILL NO LONGER WORK ACCURATELY. REPLACE THE MEMBRANE CAP WITH A NEW MEMBRANE CAP OR SEND THE SENSOR AWAY TO HAVE THE ELECTRODES CLEANED.

⚠ WARNING

Wear nitrile gloves powder free.
Avoid electrolyte contact with skin.
In case of contact, immediately rinse with water.

i IMPORTANT

The electrolyte is sensitive to oxidation: Always keep electrolyte bottle sealed after use. Do not decant electrolytes into other containers.

Do not store electrolyte beyond its "Use by" date and note the "Use by" date on the label.

As far as is possible, fill the electrolyte so that it is free from bubbles. Only use the membrane cap once.

Remove protective membrane cap (transparent) before installation and keep it for decommissioning.

SCL35 - SCL8 .

Screw on the nozzle.

Place the electrolyte bottle on the membrane cap and allow the electrolyte to press out slowly in a stream of liquid from the bottle, while at the same time constantly pulling back the bottle. The cap is completely full if the electrolyte can be seen at the bottom thread (thread not covered by electrolyte).



SCL3N - SCL11

Electrolyte is already screwed. Remove the red end cap and cut off the top end of the spout on the **second line**. The cap is completely full if the electrolyte can be seen at the bottom thread (thread not covered by electrolyte). Avoid bubbles.



SCL9

Use the pipette included to fill the membrane cap. The cap is completely full if the electrolyte can be seen at the bottom thread (thread not covered by electrolyte). Avoid bubbles.



Electrolyte (SCL2).

Produce the ready-to-use electrolyte using the set supplied for independent production of electrolyte. Unlike ready-to-use electrolyte, these individual components are not regarded as hazardous materials. Take the following steps to produce the electrolyte:

- 1 bottle of supporting electrolyte,
- 1 tube with powder,
- 1 label for the electrolyte produced.

Electrolyte production (SCL2).

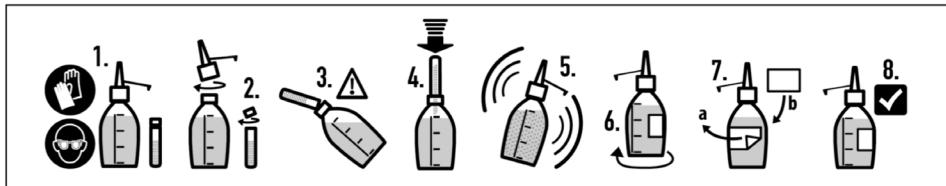

1. Take appropriate measures, such as protective gloves and goggles (1), to protect yourself, according to the Material Safety Data Sheets for the components.
2. Open the bottle of supporting electrolyte and the tube with powder (2).
3. Guide the tube at an angle fully into the opening of the bottle of supporting electrolyte (3).
4. Completely transfer the powder into the bottle of supporting electrolyte (4).
5. Close the bottle and shake the bottle until the powder has fully dissolved, 10 seconds (5). No solids and streaks should be visible in the electrolyte.
6. Remove (6) the label from the supporting electrolyte.
7. Replace (7) the label with the label supplied.
8. You can now use the electrolyte you have produced (8).

Filling with electrolyte

1. Open the electrolyte bottle and screw on the nozzle.
2. Pour in the electrolyte, preferably free of bubbles.
Place the electrolyte bottle on the diaphragm cap and slowly press the electrolyte in a single stream from the electrolyte bottle, at the same time evenly pulling back the electrolyte bottle.
The diaphragm cap is completely full if the diaphragm cap is filled to the brim with electrolyte.
3. Place the sensor vertically onto the filled diaphragm cap.
4. Do not use your finger, or similar, to close the vent hole, otherwise pressure can build up when it is screwed shut and the diaphragm can be damaged. When screwing it shut, allow excess electrolyte to escape through the vent hole under the hose seal. The vent hole must form the highest point to ensure the reliable escape of air.
If no electrolyte escapes when screwing is shut, then the diaphragm cap has not been sufficiently filled. Repeat this process and fully fill the diaphragm cap.
5. Turn the diaphragm cap manually as far as the stop so that no gap can be seen between the diaphragm cap and the sensor.
6. Rinse off any escaped electrolyte with clean water.
7. Close the electrolyte bottle.
8. Rinse the electrolyte from the nozzle of the electrolyte bottle under running water.
9. The sensor is now ready to be installed in the bypass fitting

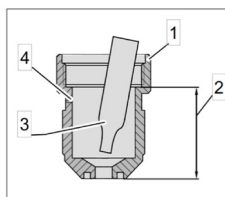

1. Diaphragm cap
2. Electrolyte filling height
3. Pipette
4. Vent Hole

Probe alignment procedure

Alignment procedure must be performed monthly or more frequently if the application needs higher precision.

The sensor needs to be calibrated to the instrument it is connected to.

Calibration must be performed to a value close to working point.

Instrument requires "0" calibration ONLY for low measurement range probes.

Instrument does not require "0" calibration if not necessary.

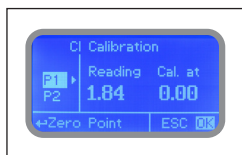
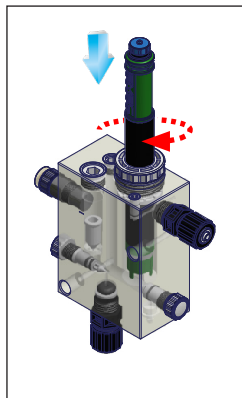

Connect the probe to the measuring instrument. Install the probe into PEF flow cell (PEF in the pictures is an example). See "**Installation on PEF**":

- close water inlet/outlet through the PEF;
 - unscrew completely the threading nut on PEF;
 - insert the probe **slowly** until the **bottom**;
 - screw the threading nut to fix the probe into the PE .
- Use **hands only**. Make sure the the probe is **tightly fastened** in the place.

To calibrate the probe:

- Open PEF water outlet and then water inlet.
- Wait the time as in "Run-in-time" on the probe technical sheet.
- Check the water chlorine by a DPD1 / DPD4 or a colorimetric method (depending on the probe).

Proceed to calibration as described on instrument manual.

*If requested, proceed to "0" calibration point
To calibrate the probe to point 0, water must be chlorine free.*

*For a chlorine free water, substitute the filter (installed before the PEF) with a carbon filter one.
Check the absence of chlorine by a DPD1 / DPD4 or a colorimetric method (depending on the probe).*

*Open PEF water outlet and then water inlet.
Wait the time as in "Run-in-time" on the probe technical sheet.*

Proceed to 0 calibration as described on instrument manual.

Cleaning procedure must be performed monthly or more if the application needs higher precision.

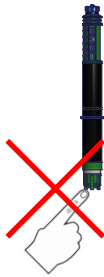

i IMPORTANT

DO NOT TOUCH OR DAMAGE THE MEMBRANE AT THE BOTTOM OF THE MEMBRANE CAP AND THE ELECTRODES AT THE BOTTOM OF THE ELECTRODE SHAFT OR BRING THEM INTO CONTACT WITH GREASY SUBSTANCES.

OTHERWISE THE SENSOR WILL NO LONGER WORK ACCURATELY. REPLACE THE MEMBRANE CAP WITH A NEW MEMBRANE CAP OR SEND THE SENSOR AWAY TO HAVE THE ELECTRODES CLEANED.

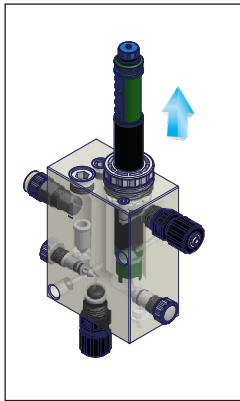

Uninstall the probe from PEF flow cell

- close water inlet/outlet through the PEF;
- unscrew completely the threading nut on PEF;
- extract the probe **slowly**.

Gently remove any adhesive dirt:

1. Rinse the membrane under a gentle stream of cold water
 2. Remove deposits (lime scale, rust):
 - Dismantle the membrane cap
 - Rinse the sensor with plenty of water
- Now fill the sensor with electrolyte, allow it to run in and recalibrate.

Replacing the membrane

If calibration is no longer possible even after the membrane has been cleaned or if the membrane is damaged, then you need to replace the membrane cap.

Repairing the sensor

The sensor can only be repaired in the factory. Return it in its original packaging.

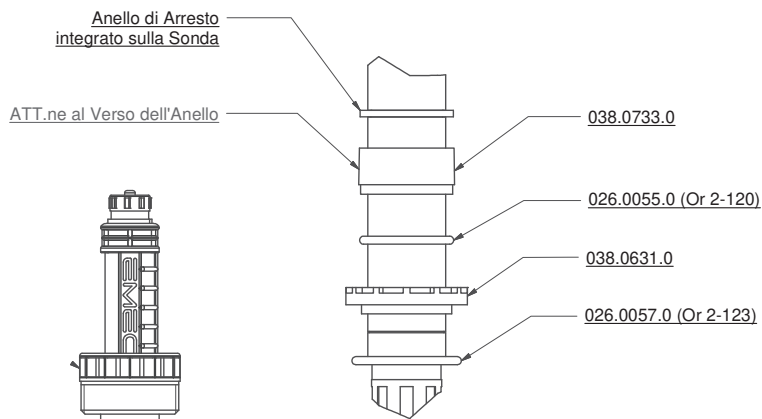

Dettaglio 1 (0.8)

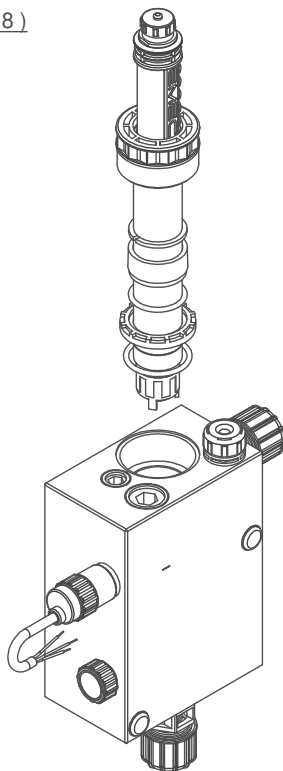
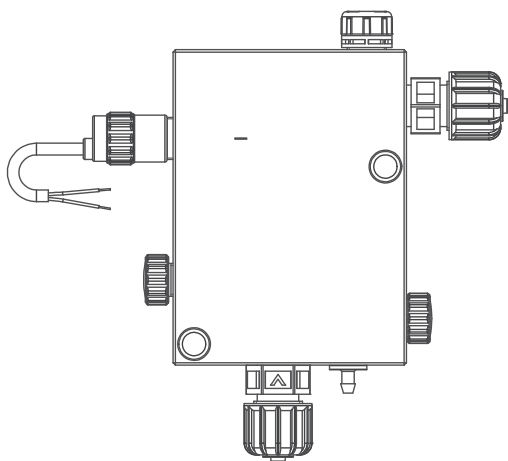
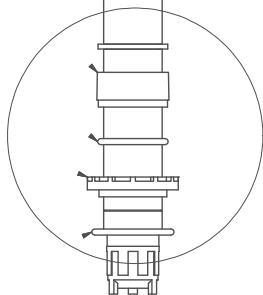

MAINTENANCE

Maintenance schedule

**⚠ DANGER
MAINTENANCE SCHEDULE**

In order to ensure the requirements of potable drinking water treated and the maintenance of the improvements as declared by the manufacturer, this equipment must be checked at least once a week.

**⚠ DANGER
OPERATOR PROTECTION**

Use safety equipment according to the company regulations.

Use this safety equipment within the work area during installation, service and when handling chemicals:

- protective mask
- unpowdered nitrile gloves
- safety goggles
- further security device, if necessary.

**⚠ DANGER
POWER SUPPLY DISCONNECTION**

Always disconnect power to the equipment before you perform any installation or maintenance tasks. Failure to disconnect power will result in serious physical injury.

**⚠ DANGER
AUTHORIZED AND QUALIFIED PERSONNEL**

Installation and maintenance tasks should be carried out by AUTHORIZED AND QUALIFIED PERSONNEL only in accordance with local regulations.

i IMPORTANT

Use original spare parts.

Maintenance inspection

INTERVAL	MAINTENANCE INSPECTIONS	REFERENCE
Weekly	Control probe reading using a DPD1/DPD4 or colorimetric method.	Probe calibration procedure
Monthly	Check probe integrity	Cleaning procedure
Monthly	Check electrical wiring	-
Every 3/6 months	Replace electrolyte solution into membrane cap. Control membrane cap integrity.	"Preparation" procedure
Yearly	Replace membrane cap.	-

Shorten the inspection intervals appropriately if the chemical is abrasive or corrosive.

Decommissioning

1. Disconnect the sensor from the power
2. Depressurise the in-line probe housing
3. Loosen the clamping screw
4. Remove the sensor slowly from the in-line probe housing
5. Screw open and empty the membrane cap over a sink or similar vessel
6. Flush the membrane and electrode with clean water and dry until free of dust
7. Loosely screw on the membrane cap to protect the electrodes
8. Replace the membrane protection cap to protect the membrane cap

Dimension (mm)

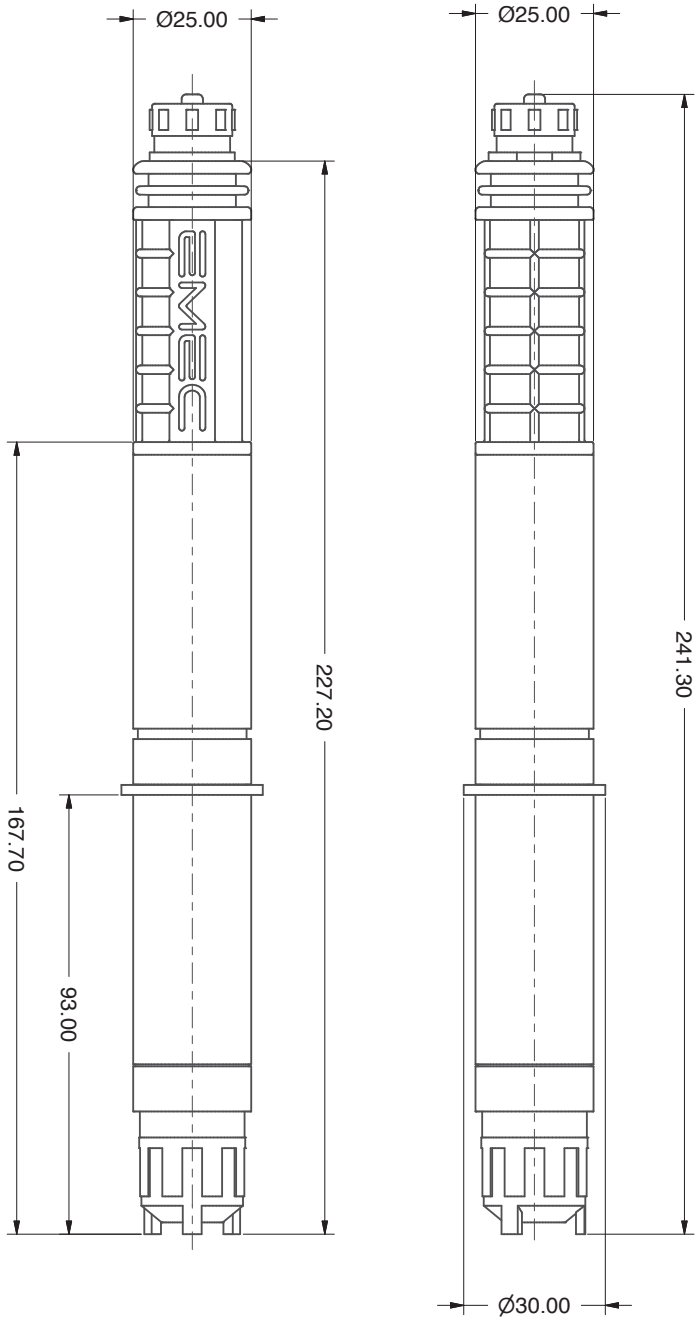

TROUBLESHOOTING

PROBLEM	CAUSES	SOLUTIONS
Sensor cannot be calibrated and measured value greater than DPD measurement	Run-in period too short	Observe the run-in period
	Membrane cap damaged	Replace membrane cap
	Troublesome substances in the water	Check water for troublesome substances and remedy this
	Distance between membrane/ electrode is too great	Screw the membrane cap up to its stop
	Short circuit in the measuring line	Identify short circuit and eliminate the cause
	DPD chemicals out of date	User new chemicals, repeat calibration
	pH < pH 5,5	Increase pH value
Sensor cannot be calibrated and measured value lower than DPD measurement	Run-in period too short	Observe the run-in period
	Coating on the membrane cap	Replace membrane cap, allow sensor to run in and calibrate
	Sample water flow rate too low	Correct flow rate
	Air bubbles on the outside of the membrane	Increase the flow within the permitted range
	pH < pH 5,5	Increase pH value
	No electrolyte in the membrane cap	Fill with new electrolyte
	Electrolyte pushed out by gas bubbles in the sample water	Contact supplier
Measured value display 0	Chlorine content below the lower limit of the measuring range	Add chlorine and then repeat calibration and/or use a suitable sensor
	Measuring line broken	Replace measuring line
	Sensor connected to the controller with incorrect polarity	Connect the sensor correctly to the controller
	Run-in period too short	Observe the run-in period
	Sensor defective	Send sensor in for regeneration
Sensor measured value is unstable	Membrane damaged	Replace membrane cap; allow sensor to run in and calibrate
	Air bubbles on the outside of the membrane	Remove air bubbles by tapping them and increase flow rate if necessary
	Reason lies with the controller	Eliminate cause

When you have tried everything: Check whether the reference electrode at the end of the electrode shaft is silvery-white instead of brownish-grey. The reference electrode is then worn out and needs to be replaced.

PRODUCT SERVICE REPAIR FORM

ENCLOSE THE PRESENT FORM TO THE DELIVERY NOTE

DATE

SENDER

Company name.....
Address

Phone no.

Contact person.....

PRODUCT TYPE (see product label)

DEVICE CODE

S/N (serial number).....

OPERATING CONDITIONS

Location/installation description

.....

Chemical

Start-up (date) Running time (approx. hours).....

REMOVE ALL THE LIQUID AND DRY IT BEFORE PACKAGING IN ITS ORIGINAL BOX.

DESCRIPTION OF PROBLEM

MECHANICAL

Wear parts.....

Brekage/other damages

Corrosion.....

Other.....

ELECTRICAL

Connections, connector, cables

Other.....

NOT OR INADEQUATE FUNCTION/OTHER

.....

.....

.....

I declare that the product is free of any hazardous chemical.

Signature of the compiler

Company stamp



Disposal of end-of-life equipment by users

This symbol warns you not to dispose of the product with normal waste. Respect human health and the environment by giving the discarded equipment to a designated collection center for the recycling of electronic and electrical equipment. For more information visit the online site.



When dismantling a pump please separate material types and send them according to local recycling disposal requirements. We appreciate your efforts in supporting your local Recycle Environmental Program. Working together we'll form an active union to assure the world's invaluable resources are conserved.