

SOIM1
SOIM3
SOIM5



SOIM1



SOIM3



SOIM2.5
SOIM5

SOPPRESSORE D'IMPULSI
PULSES DAMPENERS

IT
EN
MANUALE OPERATIVO / OPERATING MANUAL

Caratteristiche / Features

Soppressore di impulsi senza membrana.
Rivestimento interno in PP o PVDF.

*Pulses dampeners without membranes.
PP or PVDF internal coating.*

	SOIM1/V	SOIM1/D
Connessioni / Fittings	1/2"	1/2"
Volume / Volume	0.5 l	0.5 l
O-Rings / O-Rings	FKM B	EP
Corpo / Body	PVC	PVC
Temperatura max / Max temp.	45°C	45°C
Pressione max / Max pressure	5 bar	5 bar



	SOIM3/V	SOIM3/D	SOIM3K/V
Connessioni / Fittings	3/8"	3/8"	3/8"
Volume / Volume	0.09 l	0.09 l	0.09 l
O-Rings / O-Rings	FKM B	EP	FKM B
Corpo / Body	PVC	PVC	PVDF
Temperatura max / Max temp.	45°C	45°C	45°C
Pressione max / Max pressure	10 bar	10 bar	10 bar



	SOIM2.5 V/D	SOIM5 V/D
Connessioni / Fittings	1/4"	1/4"
Volume / Volume	2.5 l	5 l
O-Rings / O-Rings	FKM (V) EPDM (D)	FKM (V) EPDM (D)
Corpo / Body	PVC	PVC
Temperatura max / Max temp.	45°C	45°C
Pressione max / Max pressure	10 bar	10 bar

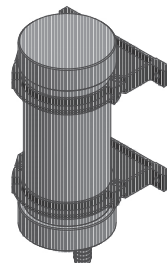

Installazione SOIM1

Posizionare il SOIM1 su un piano ORIZZONTALE e fissare con le 4 viti incluse nell'imballo.

Collegare il tubo di mandata della pompa dosatrice alla valvola di ingresso del SOIM1.

La valvola di ingresso ed uscita sono identificate da una freccia che indica la direzione del flusso.

Collegare la valvola di uscita alla valvola di iniezione.

SOIM1 installation

Fix SOIM1 on HORIZONTAL surface using the 4 screws.

Connect pump delivery hose to the SOIM1 input valve.

An arrow on input and output valves identify flow direction.

Connect output valve to injection point.

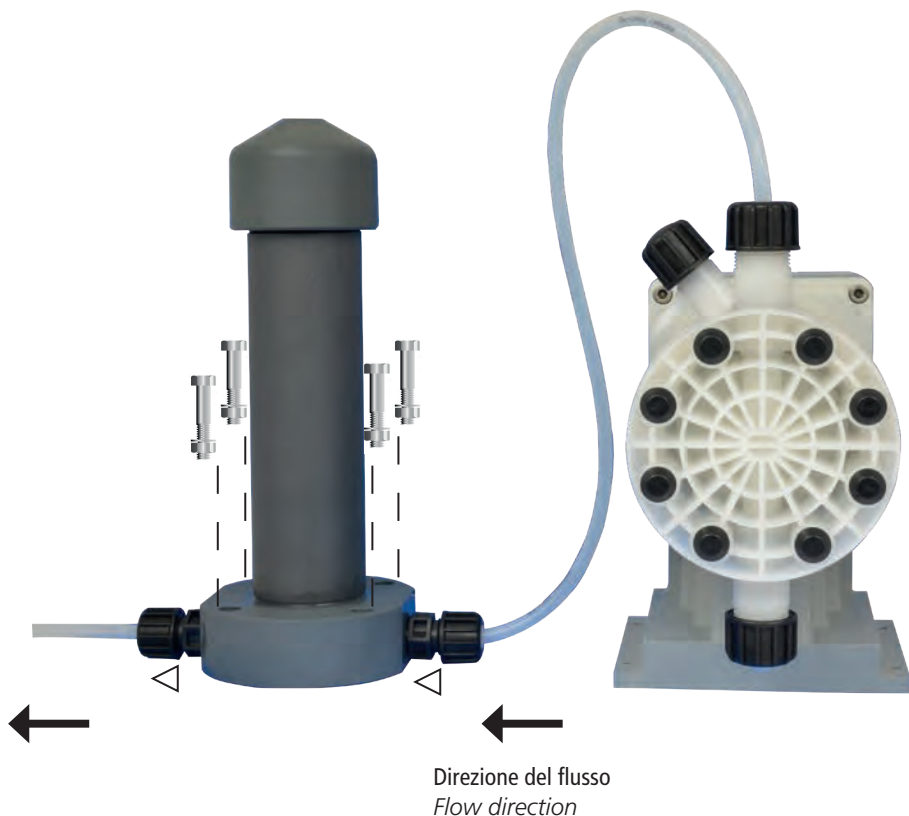

Installazione SOIM3

Fissare il SOIM3 a parete con le 2 viti incluse nell'imballo.

Collegare il tubo di mandata della pompa dosatrice alla valvola di ingresso del SOIM3.

La valvola di ingresso ed uscita sono identificate da una freccia che indica la direzione del flusso.

Collegare la valvola di uscita alla valvola di iniezione.

SOIM3 installation

Fix SOIM3 on a WALL using the 2 screws.

Connect pump delivery hose to the SOIM3 input valve.

An arrow on input and output valves identify flow direction.

Connect output valve to injection point.



Installazione SOIM5 V/D

Fissare il SOIM5 V/D a parete ad una distanza massima di 50cm dalla pompa dosatrice utilizzando le viti sui collari di supporto. Collegare il tubo di mandata della pompa dosatrice ad una valvola del SOIM5 V/D. Le valvole di ingresso ed uscita sono interscambiabili. Collegare la valvola di uscita alla valvola di iniezione.

SOIM5 V/D installation

Fix SOIM5 on a WALL. (50cm max distance from dosing pump's head) using screws on holder collars. Connect pump delivery hose to the SOIM5 V/D input valve. Input and output valves are interchangeable. Connect output valve to injection point.

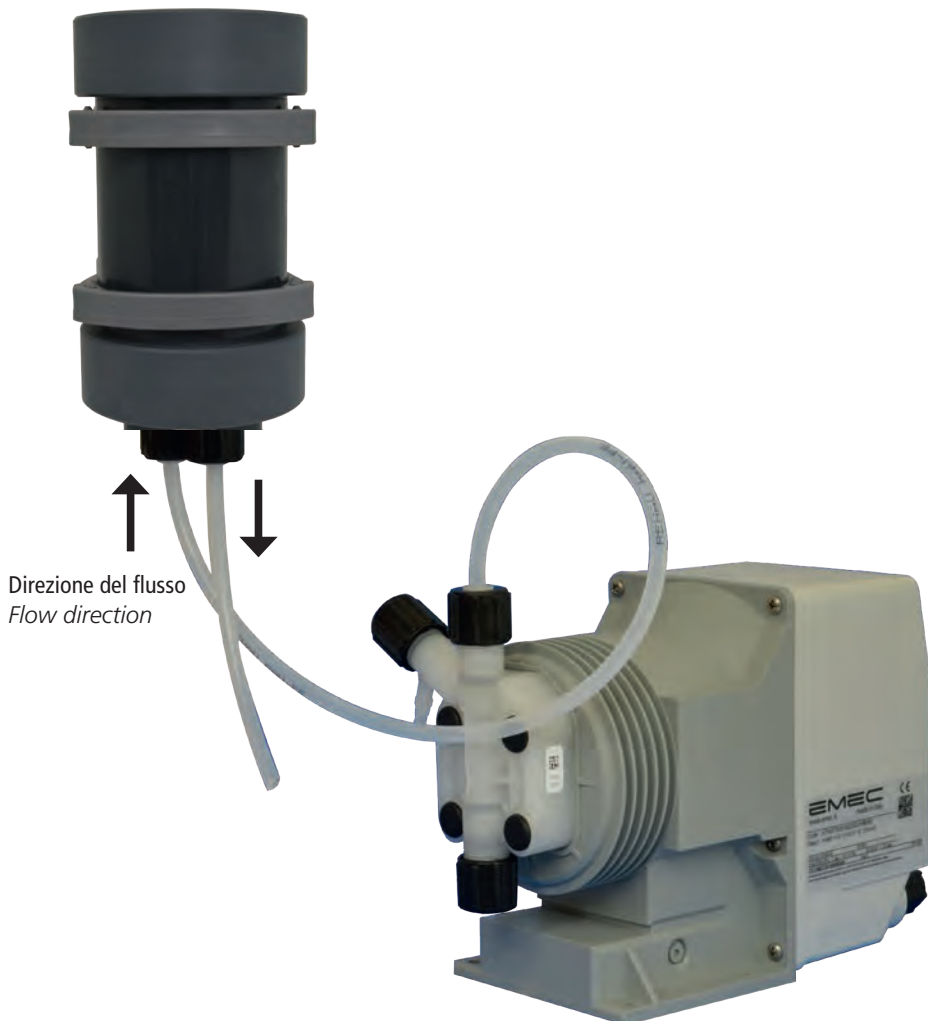

DIMENSIONI / DIMENSIONS

mm

SOIM3/V, SOIM3/D, SOIM3K/V

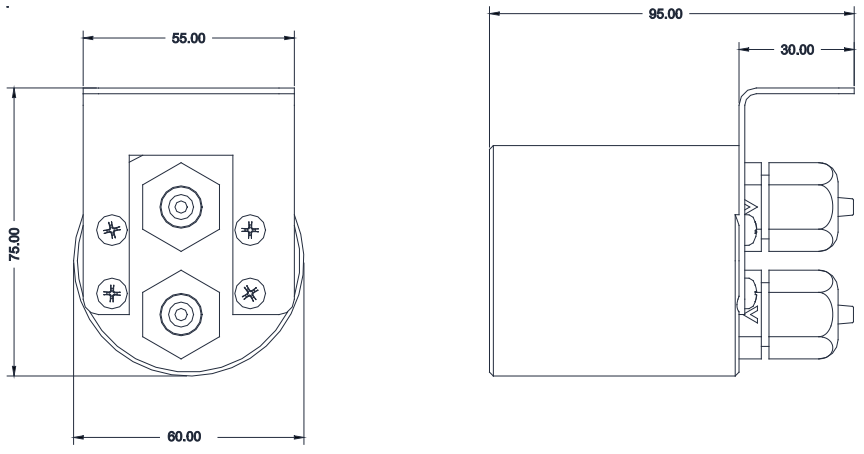

SOIM1/V, SOIM1/D

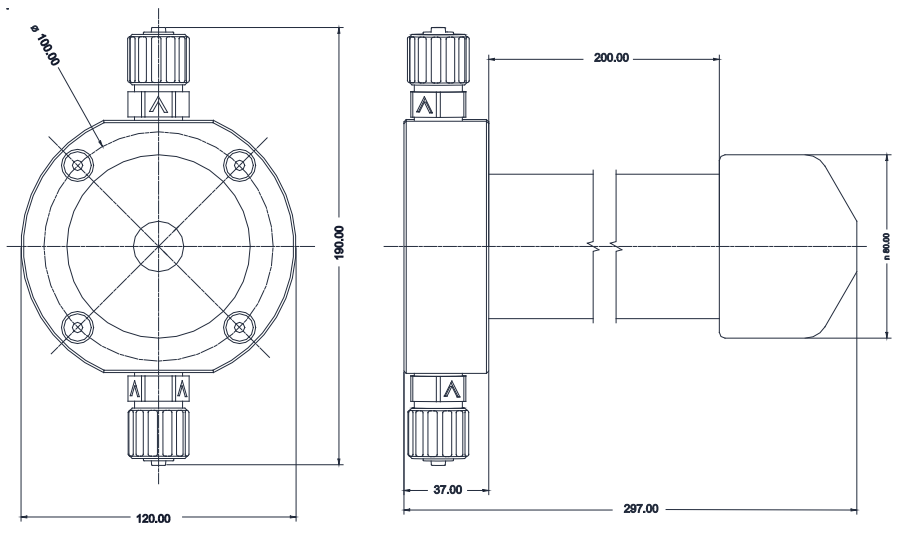

DIMENSIONI / DIMENSIONS

mm

SOIM5 V/D

