



This manual contains safety information that if ignored can endanger life or result in serious injury. They are indicated by this icon.



Keep the controller protected from sun and water. Avoid water splashes.



OPERATING INSTRUCTIONS FOR "LDOSIN PLUS" Controller SERIES



Read Carefully !



ENGLISH Version

R23-9-24



NORME CE
EC RULES(STANDARD EC)
NORMAS DE LA CE

Direttiva Bassa Tensione
Low Voltage Directive
Directiva de baja tensión } 2014/35/UE

Direttiva EMC Compatibilità Elettromagnetica
EMC electromagnetic compatibility directive
EMC directiva de compatibilidad electromagnética } 2014/30/UE



GENERAL SAFETY GUIDELINES

Danger!

In emergencies the controller should be switched off immediately! Disconnect the power cable from the power supply!

When installing always observe local regulations!

Manufacturer is not liable for any unauthorized use or misuse of this product that may cause injury, damage to persons and / or materials.

Caution!

Controller must be accessible at all times for both operating and servicing. Access must not be obstructed in any way!

Feeder should be interlocked with a no-flow protection device to automatically shut-off the pumps when there is no flow!

Pumps and accessories must be serviced and repaired by qualified and authorized personnel only!

Always discharge the liquid end before servicing the controller!

Empty and rinse the liquid end before work on a pump which has been used with hazardous or unknown chemicals!

Always read chemical safety datasheet!

Always wear protective clothing when handling hazardous or unknown chemicals!

Controller must be operated / serviced by trained technicians only!

All connection operations must be performed while the controller is not connected to main supply!

1. Introduction

LDOSIN PLUS is a digital controller for the water treatment through the REVERSE OSMOSIS process, with reading of conductivity and temperature. Main working modes are: continuous production without level control, one level control production, two levels control production with manual hysteresis and production based on quantity set. The information is shown on a large LCD display. Using a revolutionary wheel, the controller can be easily programmed. Controller is housed in a IP65 plastic box.

MAIN PRODUCTION STEPS

- 1 Low level control, activation of the input solenoid valve
- 2 Activation of the osmosis pump after a delay that can be set from the DELAY menu (default 3 sec.)
- 3 Activation of dosing pump for water inlet dosing after activation delay (default 3 sec.)
- 4 Start of reverse osmosis production
- 5 High level control and deactivation of the dosing pump
- 6 Osmosis pump deactivation after set delay (DELAY menu, default 3 sec.)
- 7 Input solenoid valve deactivation after set delay (DELAY menu, default 3 sec.)

2. The wheel

Located in the upper right side of controller there is a wheel that must be used to program the controller. Wheel can be rotated in both directions to scroll over the menus and / or pressed to confirm highlighted selection / value.

NOTE: Press "ESC" to exit without saving.

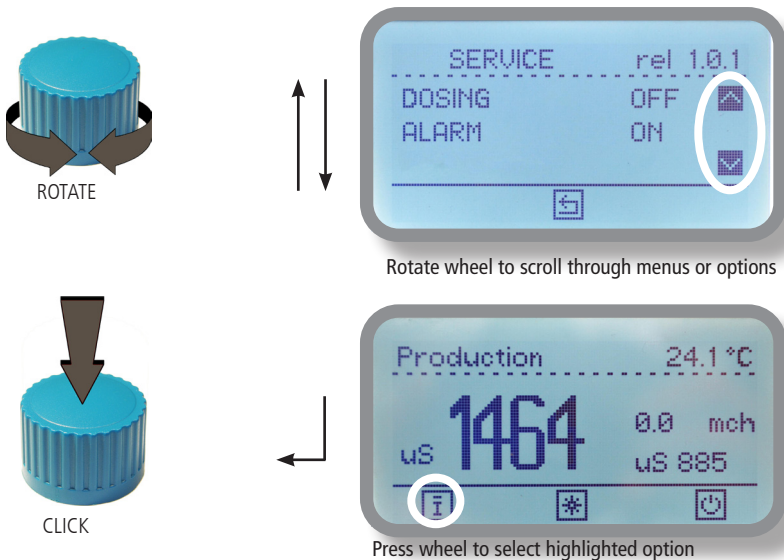

3. MAINBOARD CONNECTIONS

Unplug controller from main power supply then perform connections by following the below picture:

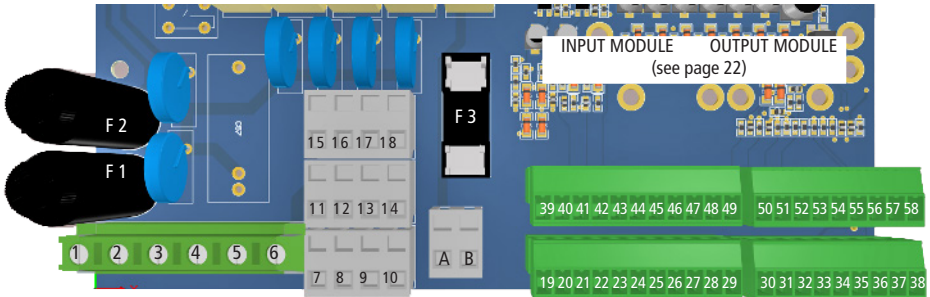

F1: Main Power Fuse (8A T) - F2: Controller Fuse (3.15A T) - F3: Free contact Fuse (2A T)

(P) Phase, (N) Neutral, (E) Earth

OUTPUTS

39(+)- 19(GND)	Current output "Input conductivity" or "Input water meter" (page 19)
40(+)- 20(GND)	Current output "Output conductivity" or "Permeate counter" (page 19)
54(+)- 55(-)	Optoisolated output (not used)
3(P) - 4(N) - 6(E)	OSMOSIS pump 230VAC (max 1,5KW) or 24VAC* 50/60 Hz
15(P) - 11(E) - 7(N)	DOSING pump 230VAC (5A max) or 24VAC* 50/60 Hz
16 (P) - 12(E) - 8(N)	EV IN 230VAC (5A max) or 24VAC* 50/60 Hz
17(P) - 13(E) - 9(N)	EV OUT 230VAC (5A max) or 24VAC* 50/60 Hz
18(P) - 14(E) - 10(N)	EV PURGE 230VAC (5A max) or 24VAC* 50/60 Hz
A-B	Main Alarm (free contact output max 2A)

INPUTS

1(P)-2(N) - 5(E)	Main power 230VAC (85-264Vac, 50/60Hz) or 24VAC* 50/60 Hz *see controller's label
41(+)- 21(GND)	LOW LEVEL input
42(+)- 22(GND)	HIGH LEVEL input
43(+)- 23(GND)	LOW PRESSURE
44(+)- 24(GND)	HIGH PRESSURE
45(+)- 25(GND)	HIGH TEMPERATURE alarm for OSMOSIS pump
46(+)- 26(GND)	OSMOSIS FILTER alarm
47(+)- 27(GND)	STANDBY alarm
48(+)- 28(GND)	DOSING PUMP alarm
49(+)- 29(GND)	GENERIC alarm (editable)
50(+)- 30(GND)	Pulse sender water meter (INPUT) max 300Hz
51(+)- 31(GND)	Pulse sender water meter (OUTPUT) max 300Hz
52(+)- 32(GND)	WM input 0/4-20mA
53(+)- 33(GND)	WM output 0/4-20mA
56 - 57 - 58	GND RS485, RS485 (+), RS485 (-) MODBUS COMMUNICATION
35(Green) - 36(Brown) - 37(White) - 38(Yellow):	PT100 temperature probe



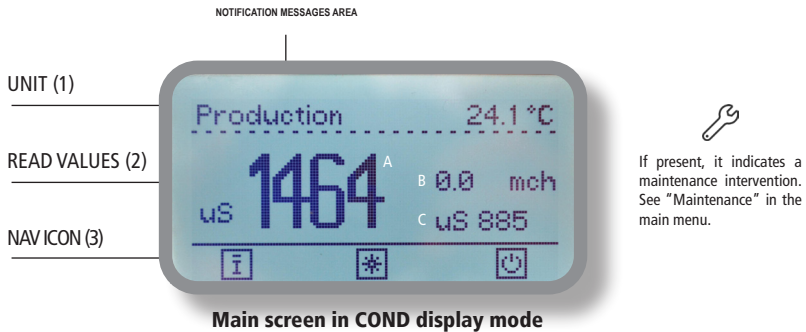

Warning: Connections must be performed by qualified and trained personnel only.

4. Main Screen

The main screen, the normal work activity of the LDOSIN PLUS controller is divided as follows:



- (1) **UNIT** The main unit of the conductivity probe may vary if the working scale is changed
- (2) **VALUES** Output conductivity values (A), input (C), production cubic meters per hour (B)
- (3) **ICONS** Move the cursor until the icons for the following functions are highlighted:

-  Service, quick status, alarms, etc...
-  Access to the main menu for controller configuration
-  POWER ON/OFF button (stop and go for controller activity)
-  Previous Menu, Main Menu

The display background, if RGB, changes color based on controller status:

GREEN: normal operation | GRAY: Standby | RED: Alarm (check status)

YELLOW: Warning (e.g.: output activation delay function active).

The main screen can be set in the following modes from the "MAIN MENU / VIEWS" menu:

COND: outlet conductivity in the foreground, water outlet and inlet conductivity displayed laterally

WASTE: outlet conductivity in the foreground and outlet water and waste (inlet water – outlet water) displayed laterally

SR and RR (Salt Rejection* and Recovery Rate): output conductivity, input conductivity and Salt Rejection are displayed on the left side of the display, while on the right side the output water, input water and Recovery Installments. When these two values are low they guarantee the efficiency of the system.

$$\text{The SR (Salt Rejection)} = ((\text{Input conductivity} - \text{Output conductivity}) / \text{Input conductivity}) * 100$$

$$\text{RR(Recovery Rate)} = (\text{WM out} / \text{WM in}) * 100$$

Salt rejection refers to the RO membrane's ability to allow the solution to pass through while preventing dissolved solids from passing through, the total dissolved solids (TDS) in the liquid is simply the salt content of the liquid, and the TDS value is proportional to the electrical conductivity.

5. Service, quick status check

From main screen click on  to main controller parameters



SERVICE	rel 1.0.1
DATE	08/08/2016
TIME	02:12:02
EV-IN	ON

Local Date

Local Time

EV-IN electrovalve status (on or off)



SERVICE	rel 1.0.1
EV-OUT	OFF
EV-PUR	OFF
PUMP	ON

EV-OUT output electrovalve status (on or off)

EV-PUR purg electrovalve status (on or off)

Main pump activity (on or off)



SERVICE	rel 1.0.1
DOSING	OFF
ALARM	ON

Chemical dosing activity (on or off)

Main alarm status (on or off)



SERVICE	rel 1.0.1
LOW PRESS	0/3
HIGH PRES	NO
TEMP PMP AL	NO

Number of try to restore low pressure (max 9, EV in ON)

High pressure alarm (yes or no)

High temperature for dosing pump alarm (yes or no)



SERVICE	rel 1.0.1
DOSING AL	NO
FILTER AL	NO
GENERIC AL	NO

Dosing problem alarm (yes or no)

Main water filter alarm (yes or no)

Generic Alarm, editable name (yes or no)



SERVICE	rel 1.0.1
STANDBY	NO
Hr PROD	0
Hr SERVICE	100

Controller STANDBY (yes or no)

OSMOSIS total production hours

Controller total working hours





PRODUCTION	---
INPUT WM	0.0
WM INPUT(mA)	---
WM OUTPUT(mA)	---

OSMOSIS production rate

Pulse Sender Water Meter Input Status

Pulse Sender Water Meter Input / Output status (mA for current WM version)

6. Password

At first start of the controller there is no password set. To set a new password with administrator privileges to enter the main menu by clicking on the icon , then select "Settings", press the dial and select "PASSWORD". Press the knob and insert a code of four numbers. Move on the icon  and press the knob to save the settings. The new administrator password is now active. To set a USER password (with limited access functions) it is necessary, after setting the administrator password, to return to the PASSWORD menu. A new screen will allow you to choose whether to set the USER or ADMIN password. To disable a password, once you have accessed the settings menu, simply select the password, choose which one to disable and enter "0000" in the password request field.

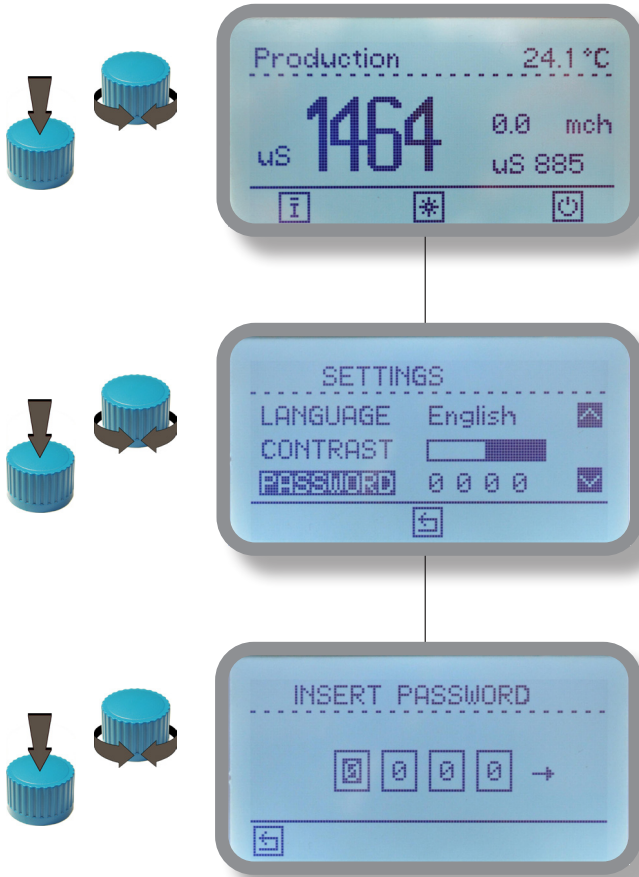

















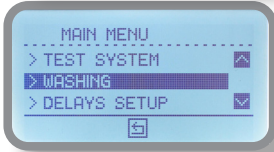





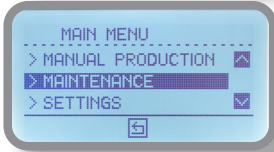









To access the "Main Menu" from the main screen, select the icon and press the dial, then enter the password (User or Administrator). Note: Do not use the same password for user and administrator.

LOST password ?

Contact your local distributor for assistance.

7. "Main Menu"

To access the "Main Menu" from the main screen, select the  icon and press the dial, then enter the password (User or Administrator).

	 <p>MAIN MENU > PROBE SETTINGS  > INPUTS SETUP > ALARM  </p>	<p>"Probe Settings" (conductivity probes setup) page 9 "Inputs setup" page 13 "Alarm" page 16</p>
	 <p>MAIN MENU > TEST SYSTEM  > WASHING  > DELAYS SETUP  </p>	<p>"Test System" page 16 "Washing" page 16 "Delays Setup" page 17</p>
	 <p>MAIN MENU > MANUAL PRODUCTION  > MAINTENANCE  > SETTINGS  </p>	<p>"Manual Production" page 17 "Maintenance" page 17 "Settings" page 18</p>
	 <p>MAIN MENU  > INSTRUMENT RESET  > mA OUTPUTS  </p>	<p>"Controller reset" page 19 "mA Outputs" page 19</p>
	 <p>MAIN MENU > COMMUNICATION  > LOG SETUP  </p>	<p>"Communication" (ERMES / SMS / Email) page 24 "Log Setup" (Events log setup) page 26</p>
	 <p>MAIN MENU > LOG SETUP > VIEW > SR and RR ALARM  </p>	<p>SR and RR Alarm (settings for Salt Rejection and Recovery Rate) Both alarms can be disabled or enabled and then set within a warning threshold and an alarm threshold (%).</p>

Click on  to exit from main menu and go to the main screen (normal working mode)

8. "Probe Settings"

Use this menu to configure all probes, calibration, configuration setpoints, temperature compensation.

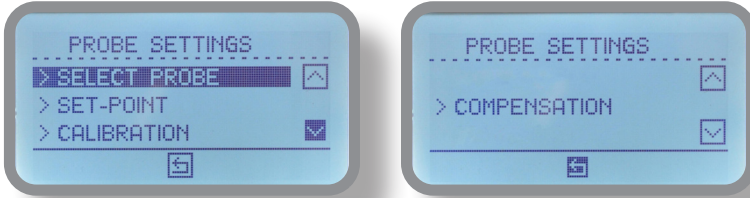

8.1 "Probe Settings / Select Probe"

Use this menu to set both the system probes (input and output), including their field of work.

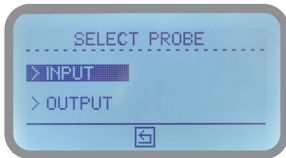

INPUT

Use this menu to set the conductivity probe input (see function diagram on page 21). Basically this sensor is installed to read the high conductivity values (HIGH CONDUCTIVITY) of the inlet water and thus before the transformation of the process of reverse osmosis. The primary display is the value (C), see page 5.

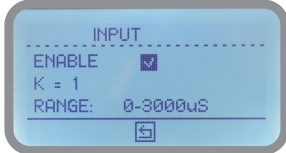

Options are:

ENABLE (leave blank to disable or "turn on" to enable)

K-Factor (enter the value shown on probe's label or probe's datasheet)

RANGE (scale of work according to the specifications of the probe)

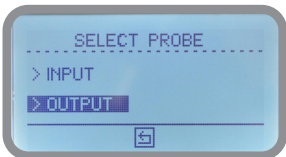

OUTPUT

Use this menu to set the conductivity probe output (see function diagram on page 21). Basically this probe is installed to read the values in the OUTPUT treated water for reverse osmosis (LOW CONDUCTIVITY). The primary display is the value (A) See page 5.

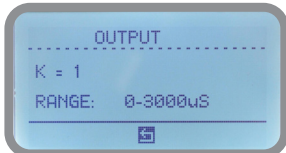

Options are:

K-Factor (enter the value shown on probe's label or probe's datasheet)

RANGE (scale of work according to the specifications of the probe)

8.2 "Probe settings / Set-Point"

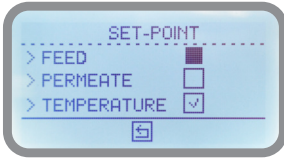

FEED (INPUT)

Use this menu to enable and set the set-point for the conductivity probe input (see function diagram on page 21). Basically this sensor is installed to read the high conductivity values (HIGH CONDUCTIVITY) of the inlet water and thus before the reverse osmosis process. The primary display is the value (C), see page 5.

Options are:

SETPOINT (maximum setpoint for high conductivity)

DELAY (max waiting time for high conductivity before enabling the alarm output and generate a message)

STOP (stop the controller when the setpoint has been reached). If not enabled the symbol Δ will be displayed in case of high conductivity read value for the input probe.

Note: "delay" does not block the activity of the Production



PERMEATE (OUTPUT)

Use this menu to enable and set the set-point for the conductivity probe output (see function diagram on page 21). Basically this probe is installed to read the values for the OUTPUT reverse osmosis water (LOW CONDUCTIVITY). The primary display is the value (A) See page 5.

Options are:

SETPOINT (minimum setpoint for low conductivity)

DELAY (max waiting time for high conductivity before enabling the alarm output and generate a message)

AFTER WASH (Check to enable the reading of immediate conductivity of the probe at the end of the membrane washing procedure)

STOP (stop the controller when the setpoint has been reached). If not enabled the symbol Δ will be displayed in case of high conductivity read value for the output probe.

Note: "delay" does not block the activity of the Production

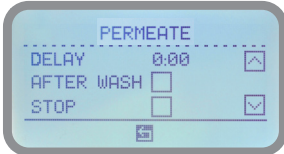
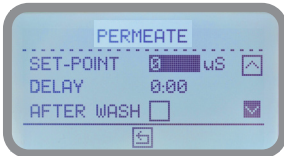

TEMPERATURE

Use this menu to enable and set the set-point for the temperature probe.

Options are:

SETPOINT (punto di consegna valore massimo prima di generare l'allarme)

DELAY (max waiting time for high temperature before enabling the alarm output and generate a message)

STOP (stop the controller when the setpoint has been reached). If not enabled the symbol Δ will be displayed in case of high conductivity read value for the temperature probe.

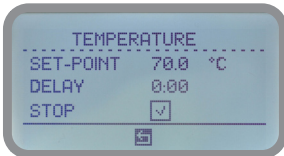

8.3 "Probe settings / Calibration"

Use this menu to calibrate both conductivity probes and the temperature probe. The calibration of the conductivity probe involves a zero calibration (ZERO) and a second calibration point (SLOPE) which requires a buffer solution having value closest to that of the working field. Note: This procedure assumes that the controller is properly installed and configured, connected to a working sensor. Perform calibration with the temperature in the system use, otherwise you may experience incorrect results. Also check that the scale of the probe is correctly set. **Calibration can be set by disabling the temperature compensation (temperature probe not connected) or by activating the temperature compensation but with temperature probe connected.**

ZERO & SLOPE for input and output conductivity probes

During this procedure probes must be dry and clean and still not installed on the system.

Select the sensor to be calibrated and then move the cursor to "ZERO". Keeping the probe in hand, with the tips exposed to the air and move the cursor to  and press the dial. Note: Normally the zero calibration is not necessary.

Now move the cursor to "SLOPE", insert the tip of the probe in a buffer solution with a value closest to that of the working field and wait for the reading shown on the controller display is stable and then press the knob to confirm and enter the value of the solution buffer, then move the cursor to "check" to confirm the displayed value. To stop the calibration procedure, select "X".

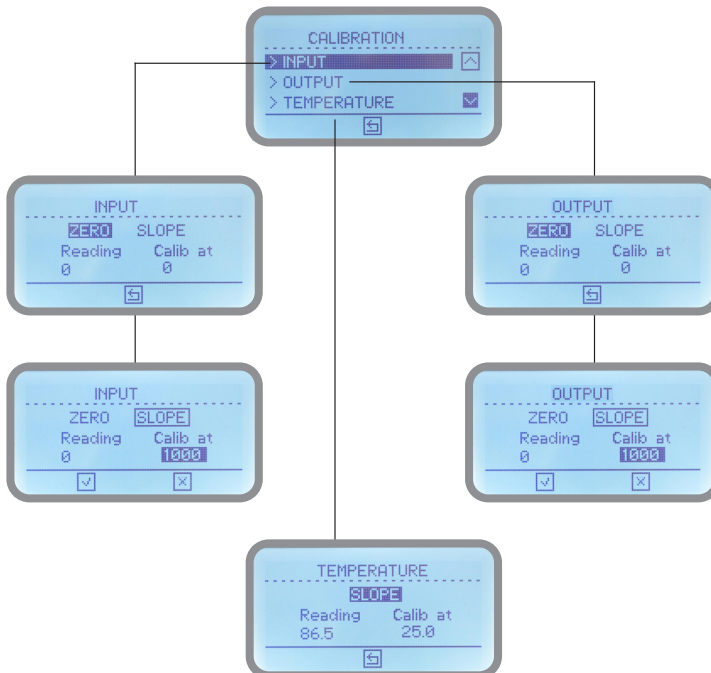

A professional thermometer is necessary to obtain a reliable calibration of the temperature probe. From "Menu Calibration" choose "TEMPERATURE". This procedure assumes that the controller is properly installed and configured, connected to a PT100 probe. Select SLOPE, quindo move the cursor to "Calib. at" and enter the value read from the thermometer temperature. Finally move on  to confirm and save acquired data.

8.4 "Probe settings / Compensation"

Conductivity measurements are temperature dependent. The degree to which temperature affects conductivity varies from solution to solution and can be calculated using the following formula:

$$G_t = G_{tcal} \{1 + a(T-T_{cal})\}$$

where: G_t = conductivity at any temperature T in °C, G_{tcal} = conductivity at calibration temperature T_{cal} in °C, a = temperature coefficient of solution at T_{cal} in °C.

Substance at 25°C	Concentration	Alpha (a)
HCl	10 wt%	1.56
KCl	10 wt%	1.88
H2SO4	50 wt%	1.93
NaCl	10 wt%	2.14

The coefficients (a) of the most known solutions are reported above.

To calculate the coefficient (a) measure the conductivity at different temperatures: for example, measure the conductivity at $T_1 = 15^\circ$ (CD1) and at $T_2 = 25^\circ$ (CD2). The coefficient (a) is the result of the division between the slope of the conductivity vs the temperature change and conductivity at calibration temperature.

$$\frac{(CD2-CD1) / (T2-T1)}{G_{tcal}}$$

Temperature compensation (Alpha) can be changed within 0.0% and 5.0%. It should be set according to measured chemical properties. If a temperature probe is installed choose "Enable" for "Automatic". Otherwise select "Disable" and enter a temperature value in "Temperature" field. If the controller is connected to a temperature probe, check the "Automatic" field: temperature compensation is automatic. Otherwise choose to leave the field blank and enter a value of average temperature in the system under which compensation must be made (field TEMPERATURE).

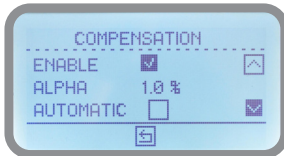

Options are:

ENABLE (tick to enable on the basis of the following parameters for the temperature compensation)

ALPHA (see explanation above)

AUTOMATIC (tick to enable automatic temperature compensation based on the reading provided by the PT100 sensor installed)

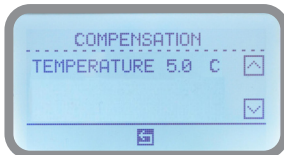

TEMPERATURE (manually enter a fixed value, if there is any installed temperature probe)

Note: If "AUTOMATIC" is enabled then the "TEMPERATURE" field is not visible.

9. "Inputs Setup"

Use this menu to enable / disable and configure all inputs including water meters.



9.1 "Inputs Setup / Level"

Use this menu to turn on / off control of high and low levels.

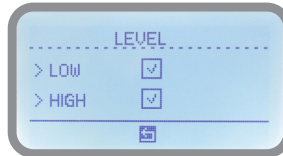

9.2 "Inputs Setup / Pressure"

Use this menu to activate / deactivate pressure check using the installed pressure switches (if available) for minimum and maximum pressure input. For MINIMUM pressure choose contact type (N.O or N.C.), the activation delay (DELAY) and the maximum number of attempts to reset before stopping the controller and enabling minimum pressure control during washing can be defined. For MAXIMUM pressure choose contact type (N.O or N.C.), the activation delay (DELAY). Note: the minimum pressure control occurs when the EV IN is open / active.

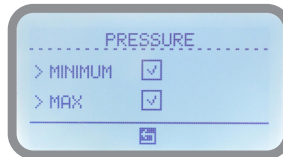

9.3 "Inputs Setup / TEMP PUMP AL"

Use this menu to enable / disable contact for the thermal control of the engine. This type of control allows that the motor of a pump is efficient (optimum operating temperature). In case an anomalous variations, outside of normal working parameters, it is possible to activate a contact to block the production of reverse osmosis in order to protect the whole system.

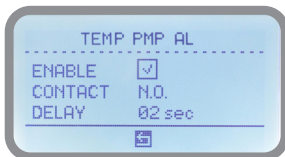

Options are:

ENABLE (enable thermal control of the pump)

CONTACT (type of available contact normally open or closed)

DELAY (alarm activation delay for the contact status change)

9.4 "Inputs Setup / Filter"

Use this menu to enable / disable the control osmosis filter if provided with a contact type N.O. or N.C. This contact allows to pause the activities of the water production until the next change of state.



The screenshot shows a menu titled "FILTER" with a dashed line above it. Below the line, there are three rows of settings: "ENABLE" with a checked checkbox, "CONTACT" with the value "N.O.", and "DELAY" with the value "02 sec". At the bottom of the menu, there is a small icon of a square with a plus sign.

Options are:

ENABLE (enable thermal control of the pump)

CONTACT (type of available contact normally open or closed)

DELAY (alarm activation delay for the contact status change)

9.5 "Inputs Setup / General"

Use this menu to enable / disable and edit the name for the input general alarm. This contact allows you to pause the activities of the reverse osmosis production until the next change for contact.

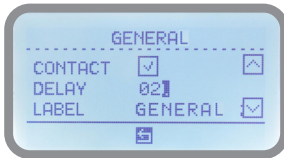

The screenshot shows a menu titled "GENERAL" with a dashed line above it. Below the line, there are three rows of settings: "CONTACT" with a checked checkbox and a small square icon to its right, "DELAY" with the value "02", and "LABEL" with the value "GENERAL" and a checked checkbox. At the bottom of the menu, there is a small icon of a square with a plus sign.

Options are:

ENABLE (enable contact)

DELAY (alarm activation delay when the contact status changes)

LABEL (change alarm rules, default: general)

9.6 "Inputs Setup / Standby"

Use this menu to enable / disable the STANDBY contact. This function stops the activity of the controller (EV IN / OUT block, EV PURGE, osmosis pump and metering pump) until the next change for contact.

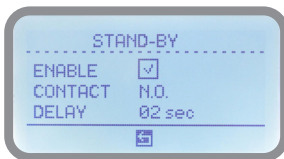

The screenshot shows a menu titled "STAND-BY" with a dashed line above it. Below the line, there are three rows of settings: "ENABLE" with a checked checkbox, "CONTACT" with the value "N.O.", and "DELAY" with the value "02 sec". At the bottom of the menu, there is a small icon of a square with a plus sign.

Options are:

ENABLE (enable contact)

CONTACT (type of available contact normally open or closed)

DELAY (alarm activation delay for the contact status change)

9.7 "Inputs Setup / Water Meter"

Use this menu to configure the mode of operation for pulse sender water meters that can be installed up to a maximum of two devices. Formally they are called "WM INPUT" (water meter placed on plant input) and "WM OUTPUT" (water meter placed at the end of the reverse osmosis water production). See function diagram on page 21 for the correct installation position.

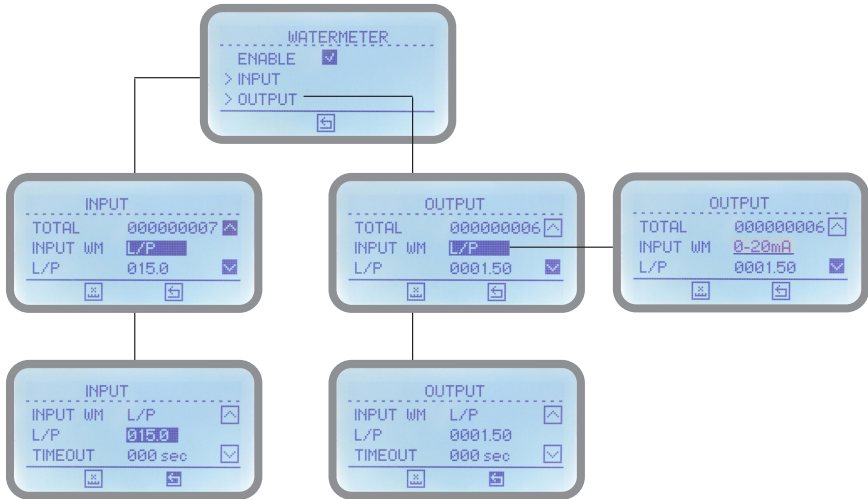

Options are:

TOTAL (showing the total amount of water passed through the pulse-emitter)

INPUTWM (choice between the following working modes: liters per pulse, pulses per liter or 0/4-20mA)

Timeout (if water meter doesn't receive pulses within the set time then the hourly amount of cubic meters displayed on the main screen will be set to zero, indicating that there is no passage of water in the system). This option operates on pulse sender WM model only.

9.8 "Inputs Setup / Dosing ALARM" (alarm contact for dosing pump)

Use this menu to enable or disable the alarm for METERING PUMP contact. This contact leads to pause production activities until next change of contact's status.

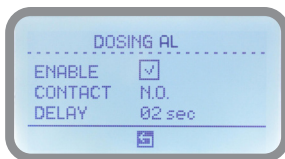

Options are:

ENABLE (enable thermal control of the pump)

CONTACT (type of available contact normally open or closed)

DELAY (alarm activation delay for the contact status change)

10. "Alarm"

Use this menu to enable or disable the alarm contact.



Options are:

ENABLE (enable contact)

CONTACT (type of available contact normally open or closed)

11 "Test System" (system verify)

Use this menu to check functionalities for the following inputs: IN-EV, EV-OUT, osmosis pump, metering pump (pump input water) and alarm contact.

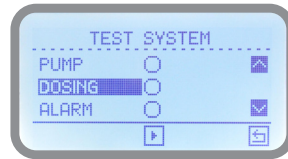
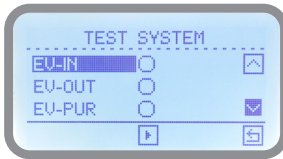

12 "Washing" (reverse osmosis membrane cleaning)

Use this menu to perform a reverse osmosis membrane cleaning.



Options are:

ENABLE (enable timed cleaning procedure)

EV-IN (if necessary enable solenoid valve input)

PUMP (if necessary activate the osmosis pump)



START PROD (start of membrane cleaning procedure before reverse osmosis production for the set period of time)

END PROD (start of membrane cleaning procedure after reverse osmosis production for the set period of time)

CYCLE (repeating the washing procedure every set Hr (hours) and for the set amount of time.

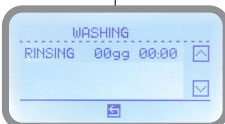

RINSING (repeating the washing procedure every set day (dd / days) and for the set period of time. The function starts only if STANDBY option is active).

13. "Delays setup"

Use this menu to set the activation delays during the production steps.

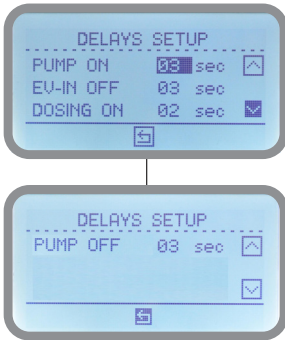

@pump On (osmosis pump start delay)

@EV-In Off (input EV disabled delay)

@Dosing ON (dosing pump delay)

@pump Off (osmosis pump stop delay)

14. "Manual Production" (reverse osmosis manual production)

Use this menu to enable the production of reverse osmosis water manually based on the amount of CBM (m³ / hour) set. Note: all security controls (level, pressure, etc ..), if available are enabled and working.

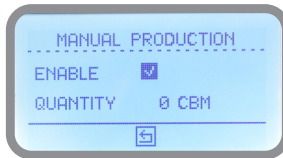

15. "Maintenance"

Use this menu to set maintenance messages every set period of time.

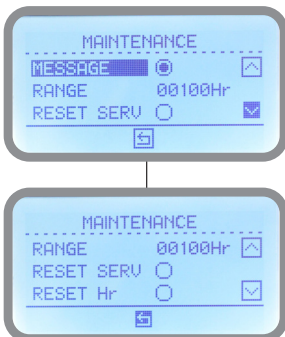

Options are:

MESSAGE (enable account for maintenance message)

RANGE (countdown for next maintenance message)

RESET SERV (reset countdown for next maintenance message)

Hr RESET (pulse sender water meter counter reset for production water)

16. "Settings"

Use this menu to choose language, format units, date and time, display contrast setting, passwords and TAU value for probes.

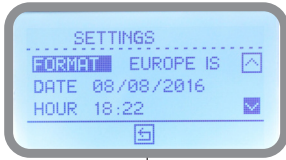

FORMAT (EUROPEAN metric units or AMERICAN, see table below)

DATE (local date)

HOUR (local time)



LANGUAGE (system language)

CONTRAST (increase or decrease display contrast)

PASSWORD (change password for main menu access)

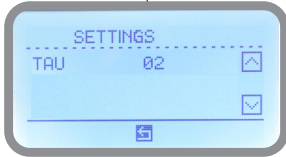

TAU (if probe's reading value is extremely unstable can be stabilized by increasing this value)

EUROPE IS (International Standard)	USA
Date (DD/MMM/YY)	Date (MMM/DD/YY)
Time 24h	Time AM / PM
°C	°F
Liters	Gallons

17. "Controller Reset"

Use this menu to reset the controller to default settings. Note: If procedure is performed with USER password login then the ADMINISTRATOR password will not be affected by this procedure.

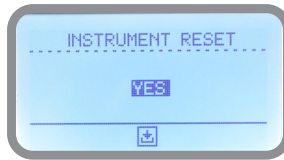

17.1 "mA Outputs"

Use this menu to configure the current outputs according to the IN and OUT conductivity reading located on terminals 39 - 19 and 40 - 20 of the motherboard.

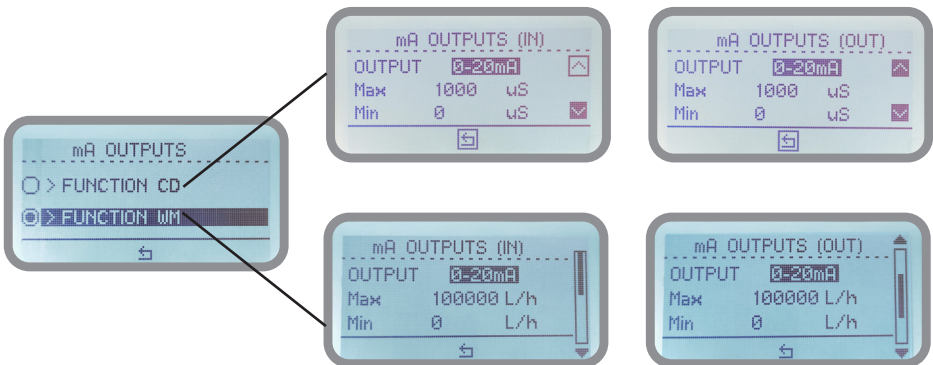

Options are:

OUTPUT (0-20mA or 4-20mA working mode)

MIN and MAX are conductivity values of the input and output probes or of the water and permeate meter

ENABLED ON ALARM (if checkbox is ticked the related output will stay enabled even during an alarm)

18. Technical Information

Power supply: 85÷264 VAC

Conductivity range: 0-3000uS ; 0-30.00mS ; 0-300.0mS ; K1 ppm ; K0.1 ppm ; K10 ppm

IN PROBE

K10 scala 30.00mS 300.0mS

K1 scala 30.00mS 3000uS

K0.1 scala 300.0 uS

OUT PROBE

K0.1 scala 300.0uS

K1 scala 3000 uS 30.00 mS

Environment Temperature: $-10 \div 45^{\circ}\text{C}$ ($14 \div 113^{\circ}\text{F}$)

Chemical Temperature: $0 \div 50^{\circ}\text{C}$ ($32 \div 122^{\circ}\text{F}$)

Installation Class: II

Pollution Level: 2

Packaging and Transporting Temperature: $-10 \div 50^{\circ}\text{C}$ ($14 \div 122^{\circ}\text{F}$)

Protection degree: IP 65

Max operating altitude 2000m (6.561feet)

19. "Logical working scheme"

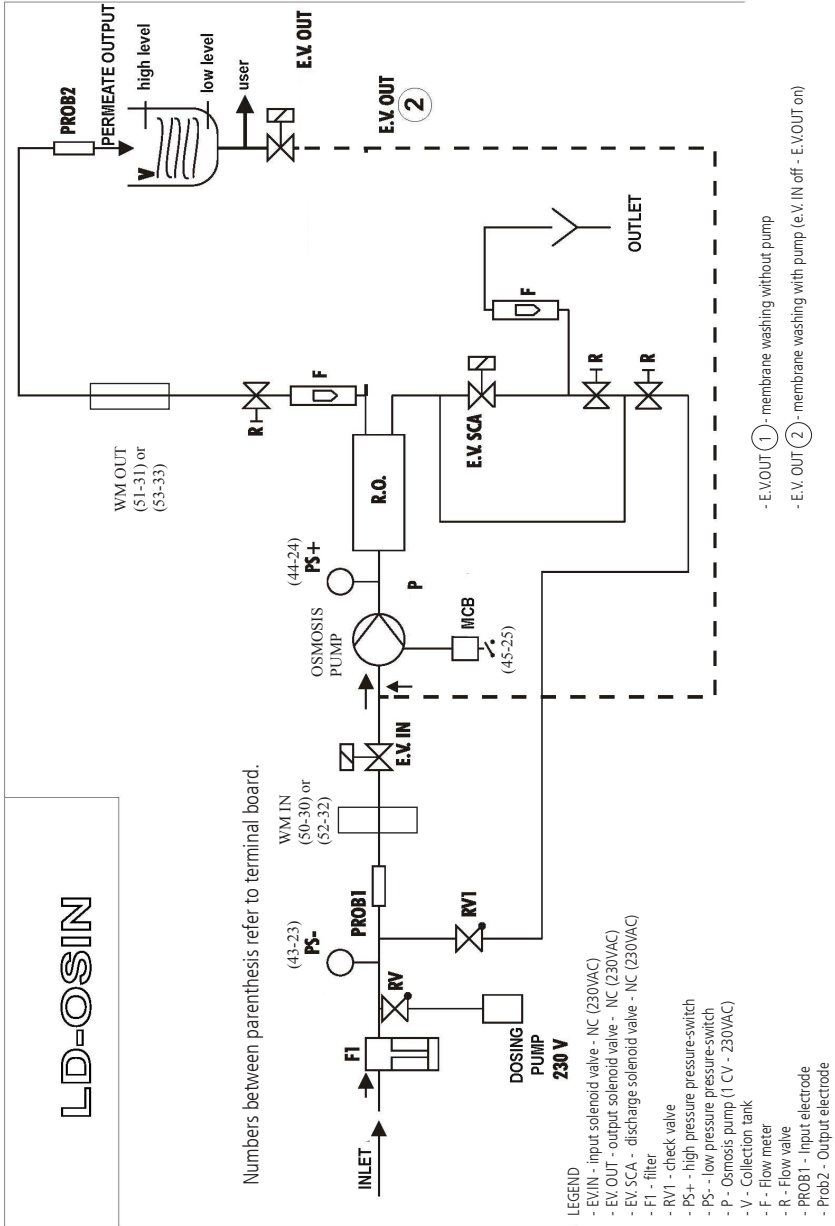

Appendix - Conductivity probe MDCDLO-A

Use the following guide to connect probes and alarms (if available):

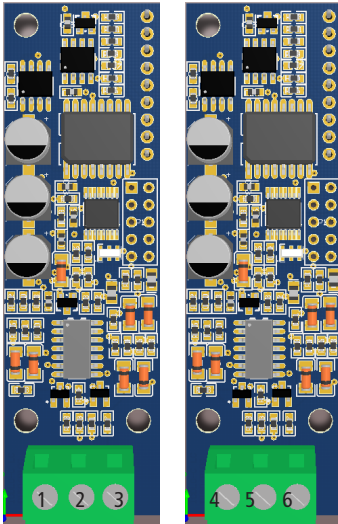

INPUT

OUTPUT

Connect Conductivity probes as follows:

- 1 n / a
- 2 Signal OUT / SYSTEM INPUT PROBE
- 3 Power IN / SYSTEM INPUT PROBE

- 4 n / a
- 5 Signal OUT / SYSTEM OUTPUT PROBE
- 6 Power IN / SYSTEM OUTPUT PROBE

Appendix - ERROR / ALARM MESSAGES

Alarms that stops controller:

1. "Error Levels": the high level closes before the low level occurs
2. "Probe's Error": communication error between the controller and the probe reading circuit
3. "Pump Temperature": high temperature for osmosis pump
4. "High Pressure": high pressure alarm in the osmosis process
5. "Low Pressure Alarm": attempts to restore pressure is exceeded
6. "High Output Conduc.": setpoint output exceeded
7. "High Input Conduc.": setpoint input exceeded if controller's lock option is enabled
8. "Probe failed": faulty probe, exceeded maximum malfunction time

Alarms that don't stops controller, the system resumes to normal operation when the contact changes its state again:

1. "Stand-by": standby alarm
2. "Dosing Alarm": dosing pump alarm
3. "Filter Alarm": plant's filter alarm
4. "General Alarm": generic alarm

"Low Pressure X / Y": Low pressure occurred. During this alarm the EV-IN remains active. After 5 minutes of alarm, try to restore the pressure by reactivating osmosis pump and the dispenser for 15 seconds. If alarm does ends the reset attempt counter increases and the sequence re-starts.

If alarm stops then normal operation resumes. If during the next 20 minutes no others alarm occur then recovery attempts counter is reset.

"Parameters Error": exit from probe setup screen, check that entered parameters are correct.

Appendix. "Communication"

Use this menu to configure communication parameters when a Ethernet, GSM or MODBUS modem has been installed.

MODEM GSM.

Install a "Data Network" enabled SIM and, if needed, enter APN parameters (including username & password). Usually these values are automatically loaded from SIM. Change them according to your SIM provider communication. If you need to receive up to 3 mobile phone numbers the controller's events messages click on "SMS1", "SMS2" and enter phone number. Note: these options need a subscription fee for data and messages traffic that IS NOT included with the modem.

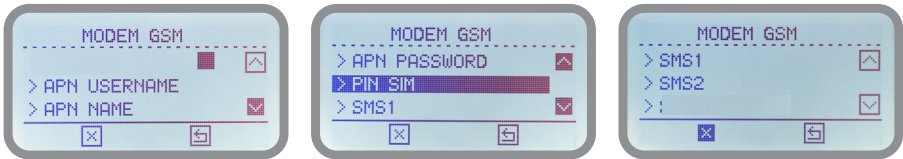

NET ADDRESSES.

Configure this menu to enable network accessibility for all controllers installed through the main one. Ask to your network administrator for values to enter. Usually just setup the communication MODE option to "DYNAMIC". For STATIC mode (IP manually assigned) enter all needed parameters: manual assigned IP, SUBNET MASK, GATEWAY (usually router IP), DNS.



MODBUS.

This protocol allows communication with PLC devices compatible with this system. Refer to the accompanying documentation for memory addresses and configure the parameters below as required by the PLC manufacturer.

MODBUS OPTION	ID: 1 BAUDRATE: 9600 FORMAT 8N1 (default)	Set ID (1 to 255). Set communication speed: 2400/4800/9600/19200/38400/115200. Set format.
-------------------------	---	--

EMAIL.

Up to 2 email address can be set to receive controller's activity / warning events log. Messages content can be set within "LOG SETUP" menu.

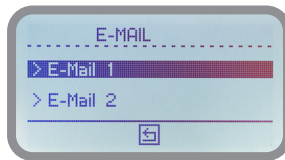

WIFI.

If a WIFI module has been installed, use this menu to associate it with an existing local wifi network.

The options are SCAN NETWORK to generate a list of available networks. Once the WIFI network has been selected, enter the password (if necessary).

Appendix. "LOG SETUP"

In order to use alarm notifications (SMS and / or Email), you must configure log options from this menu. To enable logging, select "ENABLE".



To set an hourly / daily report edit "EVERY" parameter .
This function does not manage the alarms that will still be notified to their occurrence.

Use "CONFIGURATION" submenu to select which alarms should be notified if they occur. To enable, select the required item and activate the check mark by pressing the knob.

Selectable alarms are:

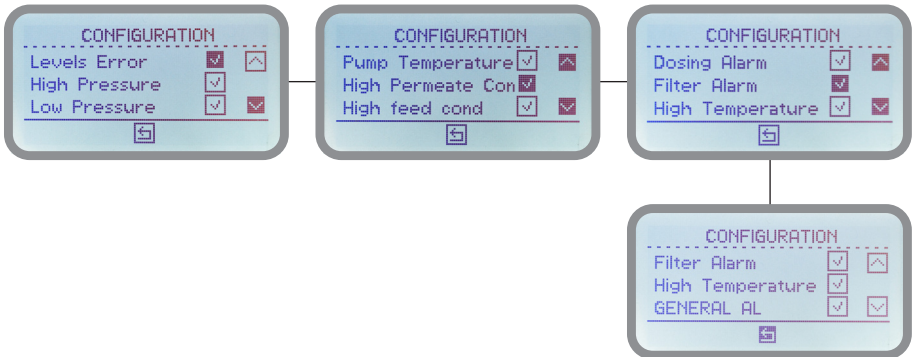

Appendix - Dimensions

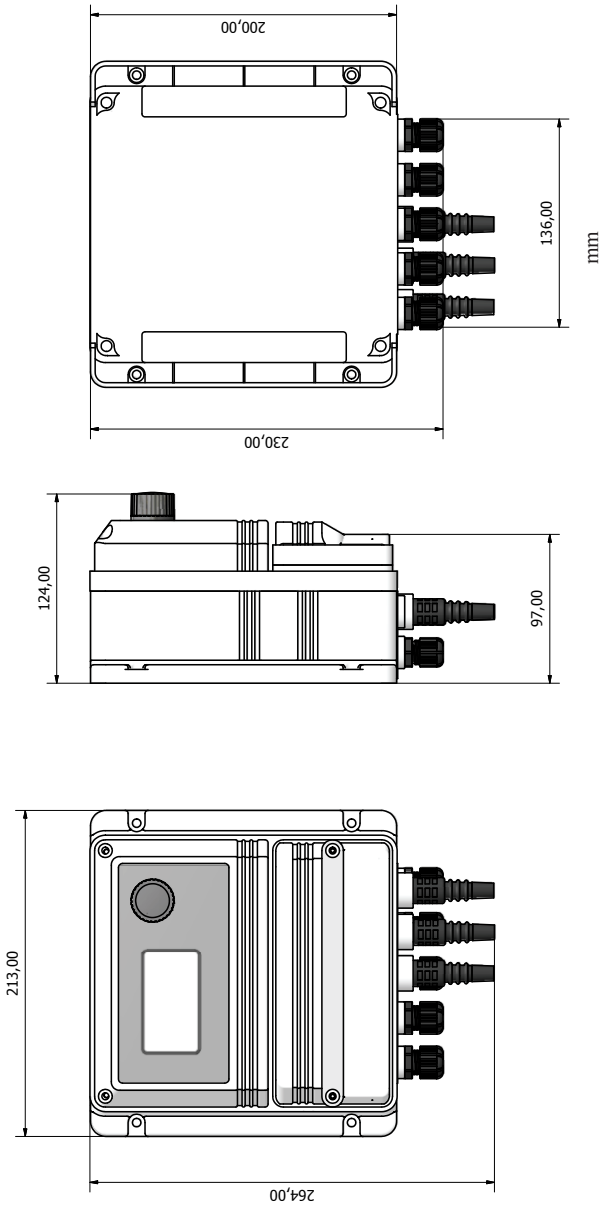

Indice

1. Introduction	3
2. The wheel	3
3. Electrical connections	4
4. Main view (main screen)	5
5. Check Status	6
6. Password	7
8. Probe settings	9
8.1 Select probe	9
8.2 Setpoint	10
8.3 Calibration	11
8.4 Compensation	12
9 Inputs setup	13
9.1 Level	13
9.2 Pressure	13
9.3 Temperature Alarm Pump	13
9.4 Filter (osmosis filter).....	14
9.5 General warning	14
9.6 Standby	14
9.7 Water Meter	15
9.8 Dosing Alarm (contact dosing pump alarm).....	15
10 Alarm	16
11 Test System (system function test)	16
12 Washing (cleaning membrane)	16
13 Delays setup	17
14 Manual production (for reverse osmosis water).....	17
15 Maintenance	17
16 Settings (General Settings).....	18
17 Controller reset & mA Outputs.....	19
18 Technical information	20
19 Logical working draw.....	21
Appendix - Probes.....	22
Appendix - Alarm messages and errors.....	23
Appendix - Communication (ERMES)	24
Appendix - LOG SETUP (Events setup)	26
Appendix - Dimensional.....	27

Information on this manual may contain technical inaccuracies or typographical errors.
The information contained may be changed at any time without prior notification or obligation.



When dismantling this controller please separate material types and send them according to local recycling disposal requirements.
We appreciate your efforts in supporting your local Recycle Environmental Program.
Working together we'll form an active union to assure the world's invaluable resources are conserved.